

St. Gobain Waste Reduction Machine

Justin Reily
Jared Hurd
Jamie Easley

Project Name

Saint-Gobain Waste Removal

Project Lead:

Jared Hurd

Members:

Jamie Easley

Justin Reily

Submitted for partial fulfillment of requirements for IT 495 senior projects class

Engineering Technology Department

Tarleton State University

04/28/2010

The following affirm that the project deliverables meets the needs of our customer and was accomplished by the project team.

Industrial Sponsor: Brent White 5/14/10

Name and Title

Date

Faculty Mentor: Greg Mott 5/14/10

Name and Title

Date

Department Approval: Greg Mott 5/14/10

Name and Title

Date

Project Leader: Greg Mott 5/14/10

Name and Title

Date

Executive Summary

Business Case

Over the past few years, Saint-Gobain's method of waste disposal has caused a significant time burden on their hands. Currently, the forklifts must run several times a week transporting the waste material from one place to another.

Current Process

The current waste removal process involves using a forklift to repeatedly push the material that has already been dumped onto the floor, and pack it into a more compact shape. It is then transported to the trash compactor and then the forklift operator will return back to the machine and repeat the process. According to our time and motion studies, the average trip from the machine to the compactor and back is approximately 1:38. The purpose of this project is to establish a method in which the waste material is in a more compact shape as it is dumped off the machine. This method is focused to dramatically help cut down on time spent for each trip from the machine to the compactor and back.

Project Scope and Goals

The Senior Project team involving the design of a new waste removal method involves Tarleton State University students and has been contracted by Saint-Gobain to help analyze the current process and provide various input and ideas to help improve it.

The objective for this project is to identify the reason behind the large time usage involving the trip from the machine to the compactor and back, and provide ideas to help improve the

situation. Our main goal for this project is to provide the customer with a more time-efficient and also cost-efficient way of transporting the waste material from one place to another. This method will help reduce the time used for each trip from the machine to the compactor and back.

Business Need

Current State

Saint Gobain is a leading manufacturer and distributor of abrasives in Texas and throughout the world. Unfortunately, due to the large amounts of waste that is accumulated throughout the day, the company has sought out for better alternatives. St. Gobain's current method of waste disposal is to let the web fall onto the floor until it piles up to the top of the conveyer. A forklift then comes and gathers the waste and takes it to the compactor where it loads the web and leaves it to be compacted. This process is costly and time consuming and it takes one forklift operator an entire shift to take care of the waste from the disc cutting machines.

The scope of this project will include researching St. Gobain's waste problem on the disc cutting machines and find a solution. The focus of the project will be to try and reduce the amount of time spent moving waste from the disc cutting machines to its final destination. The team will then design a machine that will consolidate the waste coming off of the disc cutting machine to make it easier to get rid of. Lastly, the team will deliver a completed design and bill of materials for the machine to St. Gobain before the end of the semester.

Project Strategy

Saint-Gobain has requested that the Senior Project team work with their staff to develop a possible solution to the current waste consolidation problem. They that the students, with no knowledge of Saint-Gobain's current practices can help bring fresh and innovative ideas to the table. As defined by Saint-Gobain, the main deliverable from the Senior Project team will be a design for a new waste reduction system. This design will focus strongly on reducing time and labor costs, substantially. In order for the Senior Project team to produce a successful design, industrial engineering tools including CAD programs, Gantt charts, and time and motion studies will be used to help analyze the data provided by Saint-Gobain to help better understand the current problems associated with the current process and, therefore, come up with a better alternative. The Senior Project team will perform time and motion studies to get a good understanding of the current process, identify what errors can be corrected and find ways to improve upon them in a timely manner. Next, the new design will be modeled by the CAD program, Inventor 2010. This will help the Senior Project team, as well as the customer to discuss their likes and dislikes about the design as well as any possible improvements that can be made. The focus of this is to pinpoint any possible flaws with the design and discuss them amongst the group and with the customer. Lastly, the Senior Project team will make final revisions on all drawings and discuss them with the customer. Based on this tool, the team will proceed with creative, yet realistic alternatives to current tasks. A savings analysis of all recommendations will be constructed in order to help establish all proposals.

Recommendations

- The solution is focused to help with the waste reduction in Saint-Gobain's facility. It will be used to help cut down on time and labor costs.
- Benefits of this project will involve dramatically reducing the time allotted for each forklift to travel from the machine to the compactor and back, which is currently approximately 5 minutes. Also, with the reduction in time needed, it will also help with potential eliminating the need for more workers to deal with this problem. What this will do is greatly reduce labor costs, and therefore increase the potential for more productivity.

Deliverables

Saint –Gobain will receive the following:

- Detailed information on all parts being used.
- Detailed and finalized drawings regarding the improved design.
- A thorough final report that will include all necessary detailed information regarding the current process and the new design.

Return on Investment for the St. Gobain Waste Consolidation Machine.

The return of investment was calculated with the overall cost of the machine being approximately \$8,000 and the overall salary of the forklift operator making an average of \$44,000 a year. The time for the forklift operator to make one trip averaged out at 5 minutes 38 seconds. The average trips per shift fell between 8 and 10. The average pay per hour of a forklift operator working 8 hours a day five days a week is \$21.00. Multiply the average time it takes the forklift operator to make a round trip with the average times that they have to make the trip $5.38 \text{ min} \times 10 \text{ trips} = 53.8 \text{ minutes}$ spent per machine per shift. This totals up to be 161.4 minutes on all three machines ($5.38 \text{ min} \times 3 \text{ machines}$). That is a 2.73 hour block of time that can be reduced to a 10.74 minute block of time by reducing the trips the operator takes from 10 per shift to 2 per shift. The money saved per shift is the operators hourly wage (21.00) $\times 2.51 \text{ hours} = \52.71 a shift. Multiply this by 2 shifts a day and there is a $\$52.71 \times 2 = \105.42 savings per day. Multiply this by 5 days a week $\$105.42 \times 5 \text{ days} = \527 a week . Extend this savings to the one year mark and it's a total of \$27,404 a year saved in just the forklift operators labor. At an average cost of \$8,000 a machine the three machines totaling approximately \$24,000 would pay for itself in less than a year. This has not taken into account the amount saved on the wear and tear on the compactor that the waste used to have to go into. This is not as easy to calculate but at the rate that the loads were being compressed we have been led to assume that the savings would definitely have an impact.

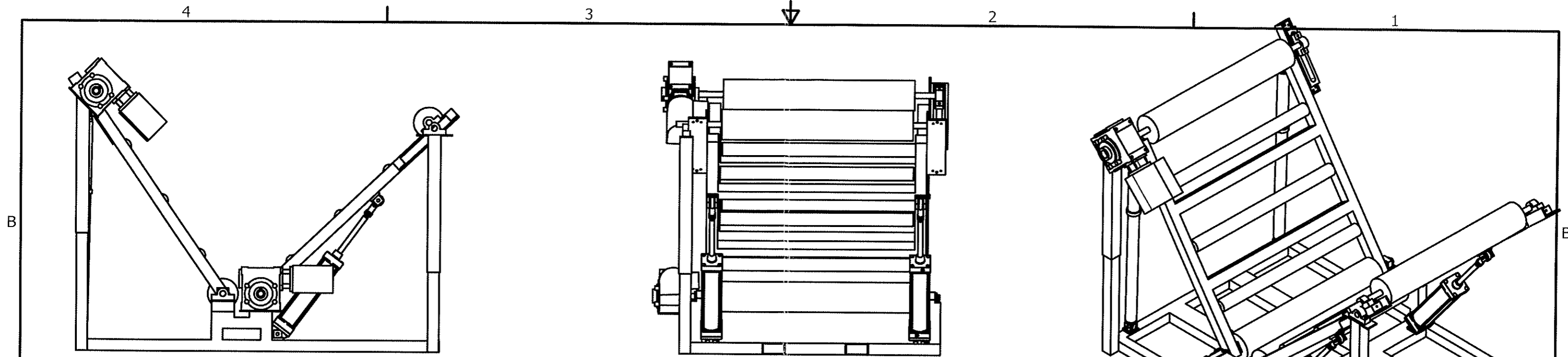

PARTS LIST

| ITEM | QTY | PART NUMBER | DESCRIPTION |
|------|-----|--|-------------|
| 1 | 1 | StGobainFrame2 | |
| 2 | 4 | Saint-Gobain Flange Bearings | |
| 3 | 4 | Saint-Gobain Eye Bracket | |
| 4 | 4 | Clevis Bracket | |
| 5 | 4 | Saint-Gobain 8 in rollers | |
| 6 | 2 | StGobainRollerFrame2 | |
| 7 | 2 | StGobainTurnbuckle | |
| 9 | 1 | Saint-Gobain Outer Support Tube | |
| 10 | 2 | Saint-Gobain Inner Support Tube | |
| 11 | 1 | Saint-Gobain Angle Brackets | |
| 12 | 5 | Pillowblock Bushing | |
| 13 | 3 | Saint-Gobain Boston Block Adjustment | |
| 14 | 3 | Saint-Gobain Boston Block Adjustment Mount | |
| 15 | 2 | Imported_1 | |
| 16 | 2 | Imported | |
| 17 | 4 | Saint-Gobain Air Cylinder Clevis | |
| 18 | 2 | Saint-Gobain Gearbox | |
| 19 | 2 | Saint-Gobain Gearbox Mount | |
| 20 | 1 | Saint-Gobain Gearbox Support Tube | |
| 22 | 2 | Saint-Gobain Motor | |

| | | | |
|--------------------|-----------|---|--|
| DRAWN st_easley | 3/29/2010 | Jamie Easley, Jared Hurd, Justin Reilly | |
| CHECKED | | TITLE DISC ROLL CUTTER WASTE ROLLER | |
| QA | | | |
| MFG | | | |
| APPROVED | | | |
| SIZE B | DWG NO | Saint-Gobain Assembly2 | |
| SCALE .04:1 | | REV | |
| | | SHEET 1 OF 1 | |

4

3

2

1

B

B

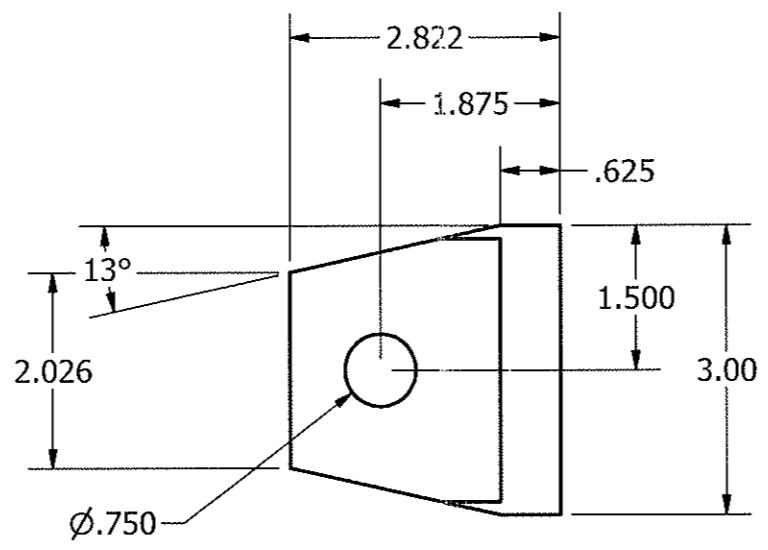
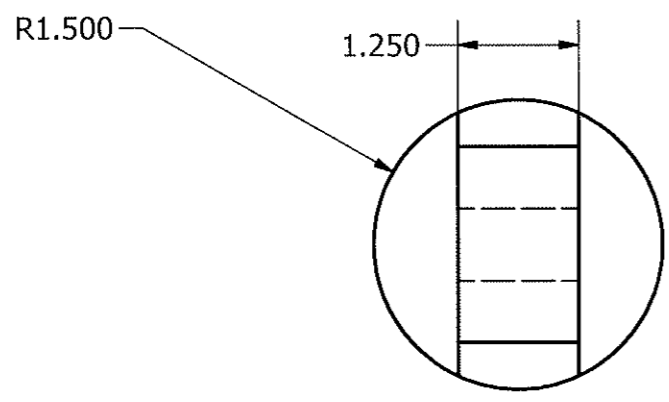
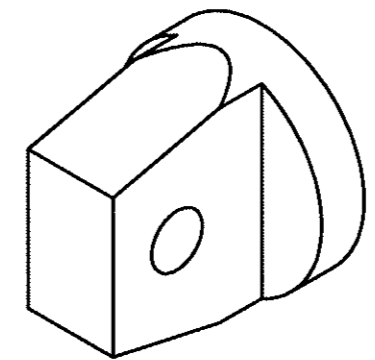
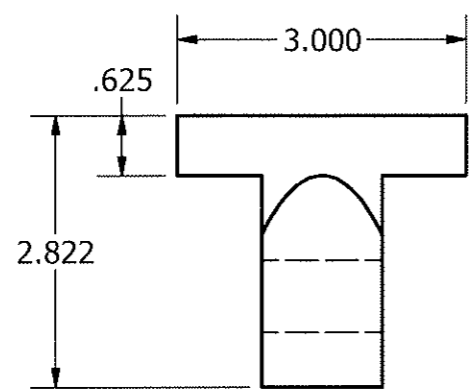

A

A

A

A

4

3

2

1

| | | | | |
|----------------|-----------|-----------------------------------|------------------------------------|-----|
| DRAWN Jamie | 5/14/2010 | TITLE INNER CLEVIS BRACKET | | |
| CHECKED | | | | |
| QA | | | | |
| MFG | | | | |
| APPROVED | | SIZE B | DWG NO Saint-Gobain Eye Bracket | REV |
| | | SCALE | SHEET 1 OF 1 | |

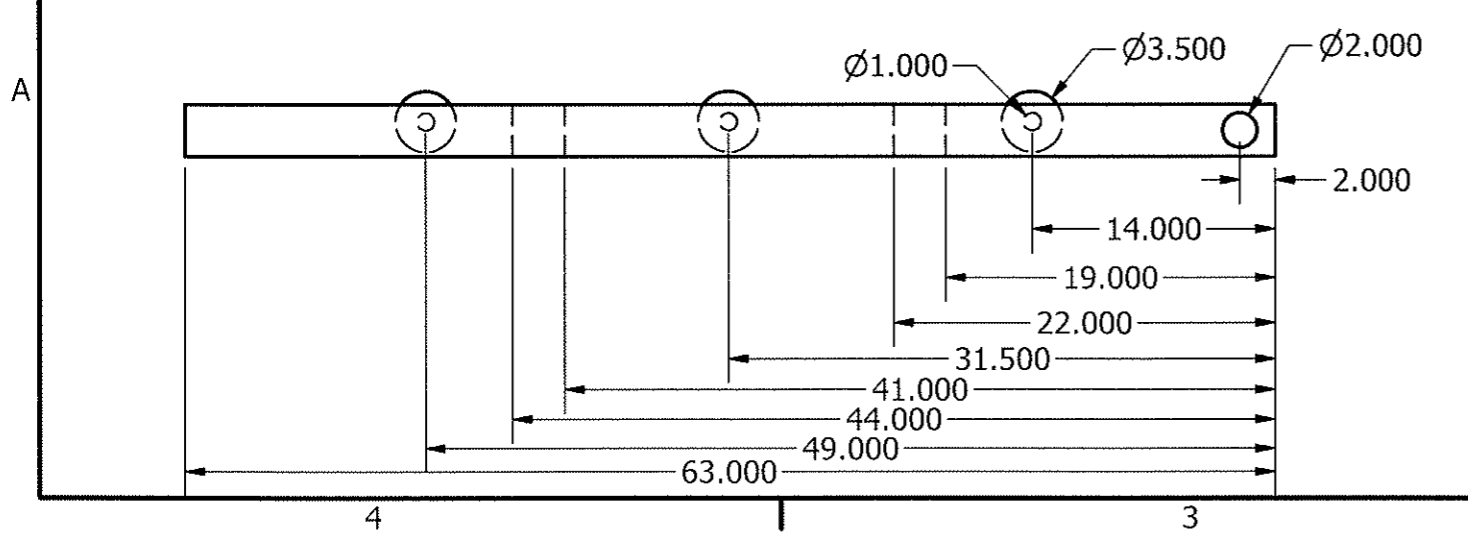
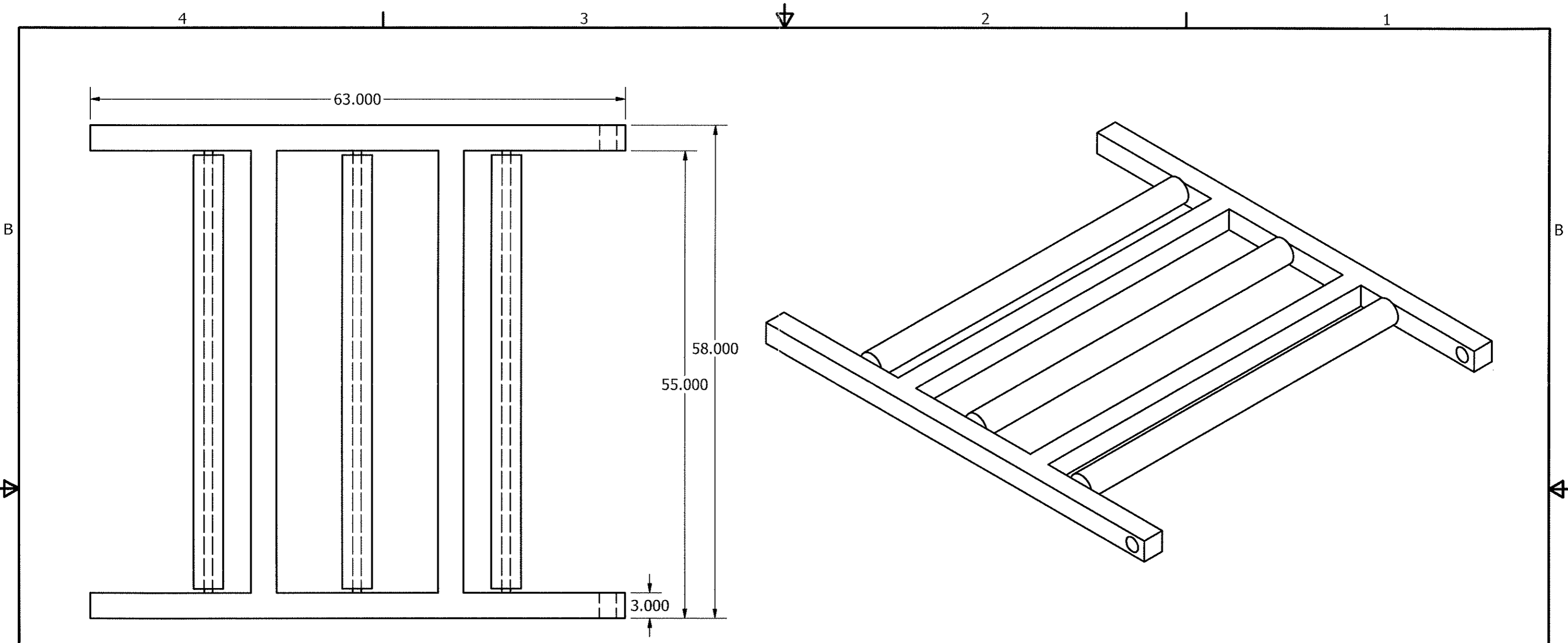

| | | | | |
|----------------|-----------|---------------------------------------|--|--------------|
| DRAWN Jamie | 5/14/2010 | TITLE ROLLER SUPPORT FRAME | | |
| CHECKED | | | | |
| QA | | SIZE B | | |
| MFG | | | | |
| APPROVED | | DWG NO StGobainRollerFrame2 | | REV |
| | | SCALE | | SHEET 1 OF 1 |

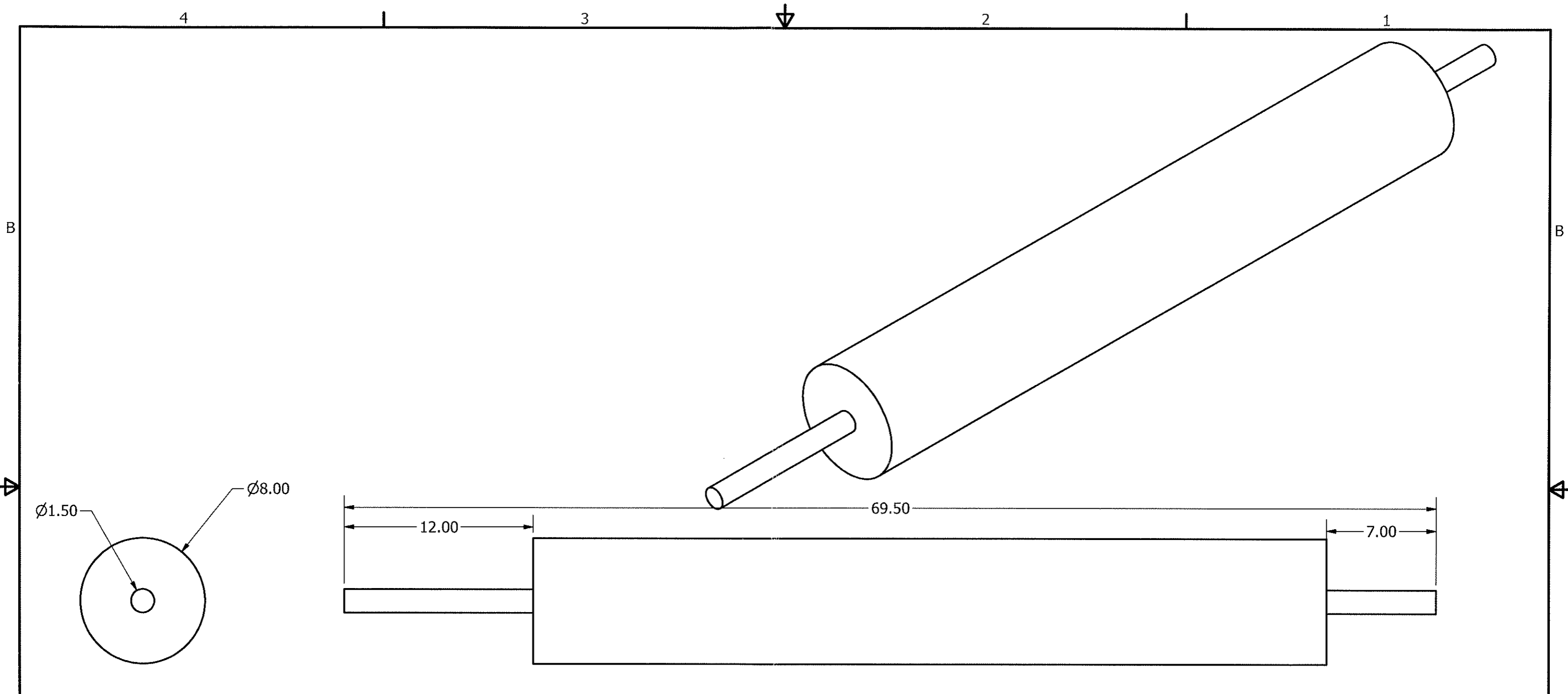

| | | | | |
|----------------|-----------|-----------------------------|--------------|-----|
| DRAWN Jamie | 5/12/2010 | TITLE 8 IN Roller | | |
| CHECKED | | | | |
| QA | | | | |
| MFG | | | | |
| APPROVED | | SIZE B | DWG NO | REV |
| | | Saint-Gobain 8 in rollers | | |
| | | SCALE | SHEET 1 OF 1 | |

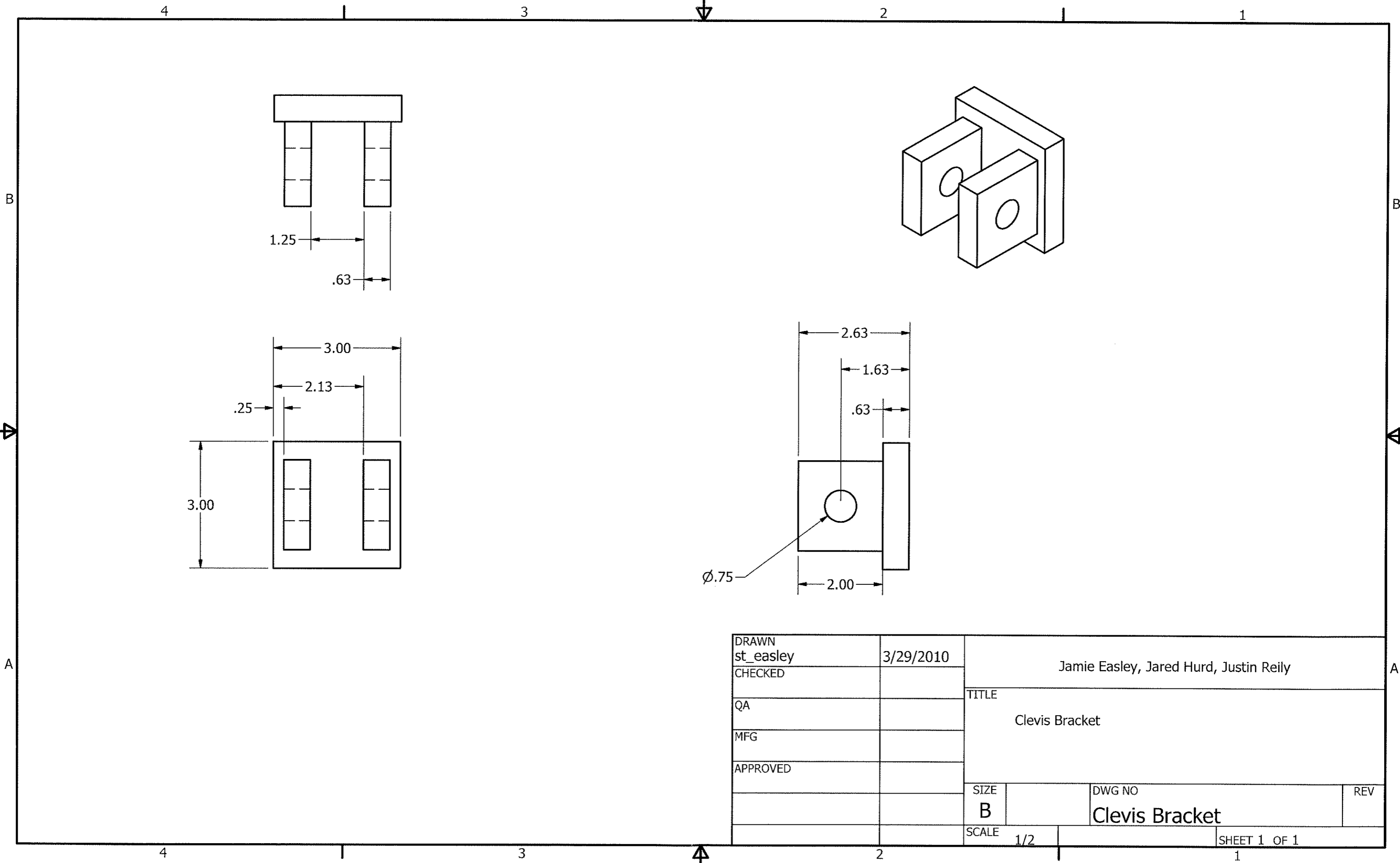

| | | | | |
|--------------------|-----------|--|---------------------------------|-----|
| DRAWN st_easley | 3/29/2010 | Jamie Easley, Jared Hurd, Justin Reily | | |
| CHECKED | | TITLE Clevis Bracket | | |
| QA | | | | |
| MFG | | | | |
| APPROVED | | | | |
| | | SIZE B | DWG NO Clevis Bracket | REV |
| | | SCALE 1/2 | SHEET 1 OF 1 | |

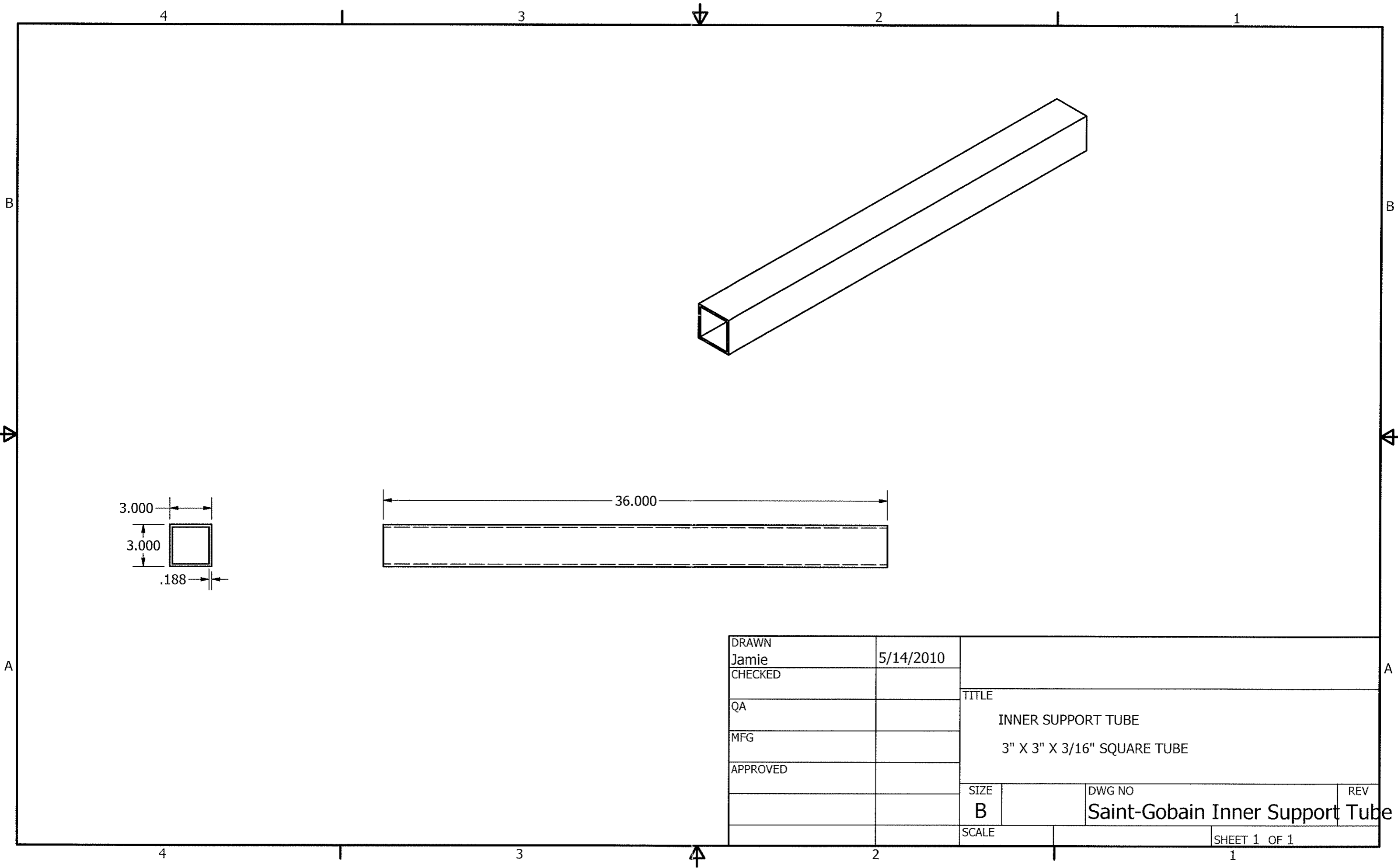

| | | | | |
|----------|-------|-----------|-----------------------------|--|
| DRAWN | Jamie | 5/14/2010 | | |
| CHECKED | | | | |
| QA | | | TITLE | |
| MFG | | | INNER SUPPORT TUBE | |
| APPROVED | | | 3" X 3" X 3/16" SQUARE TUBE | |
| | | | SIZE | DWG NO |
| | | | B | Saint-Gobain Inner Support Tube |
| | | | SCALE | REV |
| | | | | SHEET 1 OF 1 |

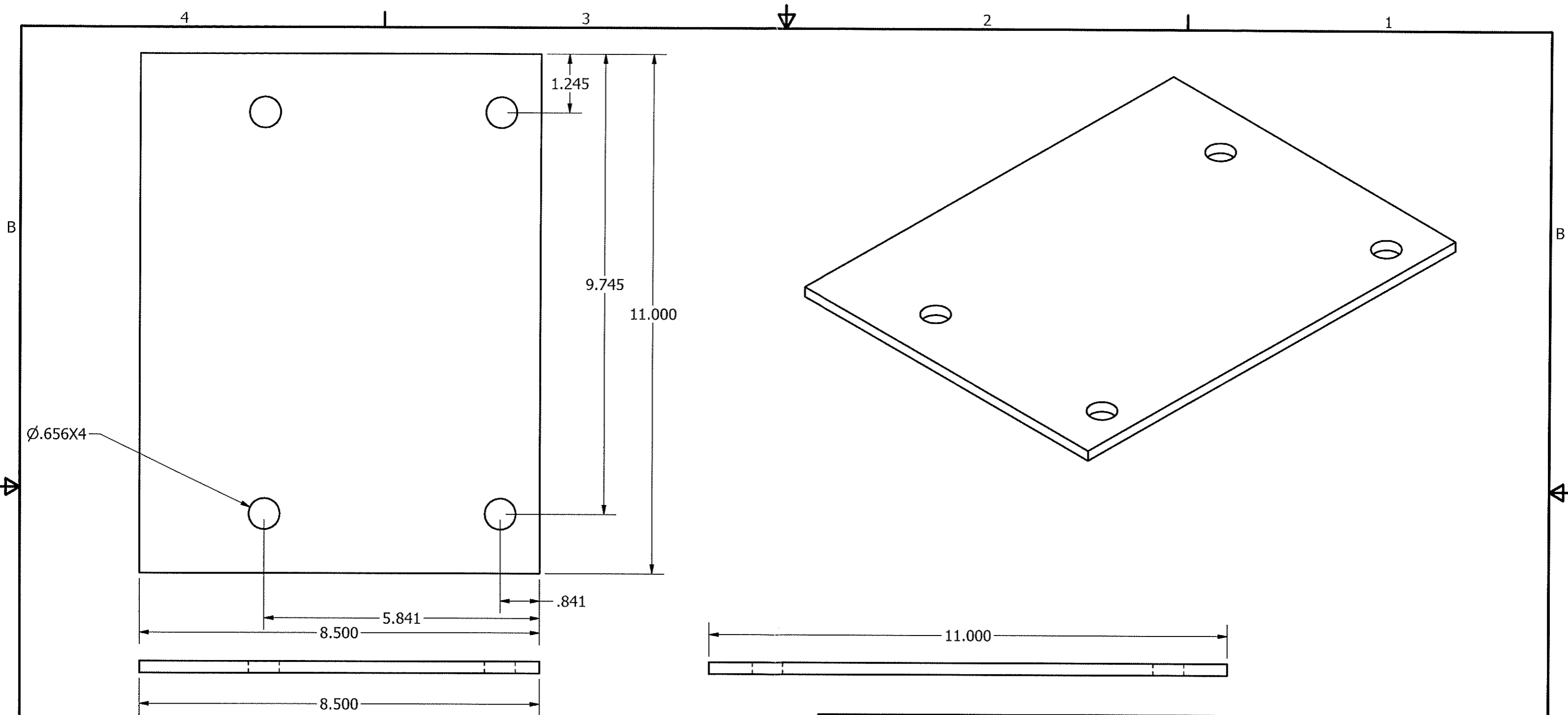

| | | | | |
|----------|-------|-----------|------------------------|----------------------------|
| DRAWN | Jamie | 5/14/2010 | | |
| CHECKED | | | | |
| QA | | | TITLE | |
| MFG | | | GEARBOX MOUNTING PLATE | |
| APPROVED | | | | |
| | | | SIZE | DWG NO |
| | | | B | Saint-Gobain Gearbox Mount |
| | | | SCALE | REV |
| | | | | SHEET 1 OF 1 |

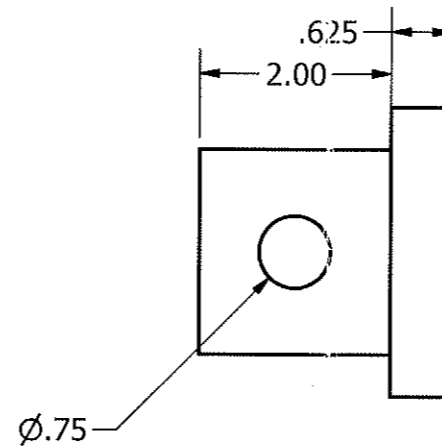
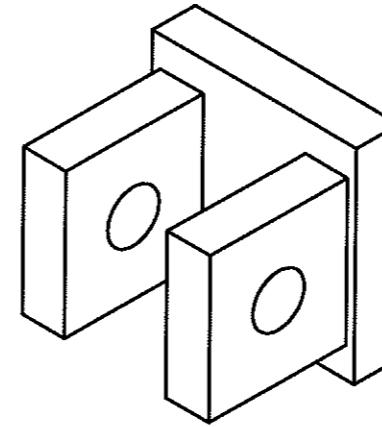
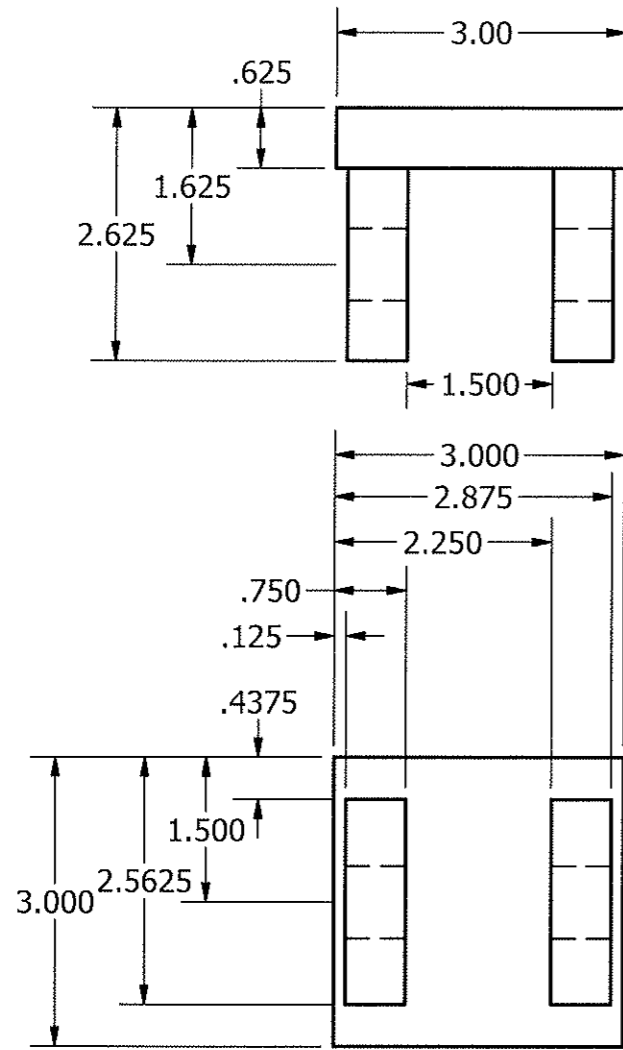

| | | | | |
|----------------|-----------|--|--|--|
| DRAWN Jamie | 5/13/2010 | TITLE AIR CYLINDER CLEVIS BRACKET | | |
| CHECKED | | | | |
| QA | | SIZE B | | |
| MFG | | | | |
| APPROVED | | DWG NO Saint-Gobain Air Cylinder Clevis | | |
| | | | | |
| SCALE | | REV | | |
| | | SHEET 1 OF 1 | | |

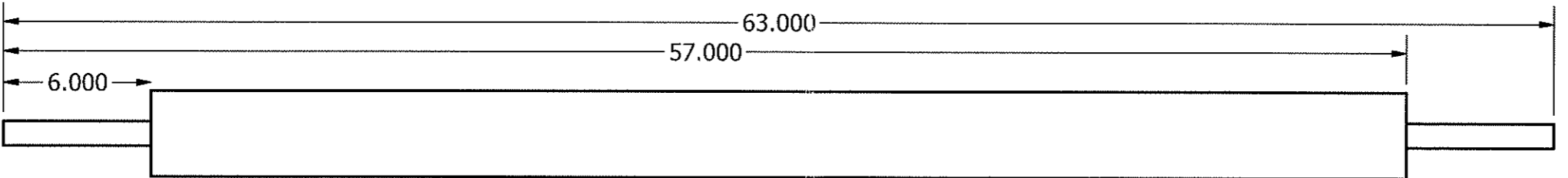
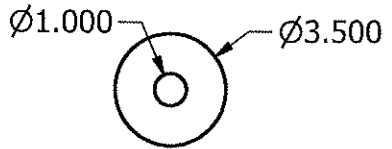
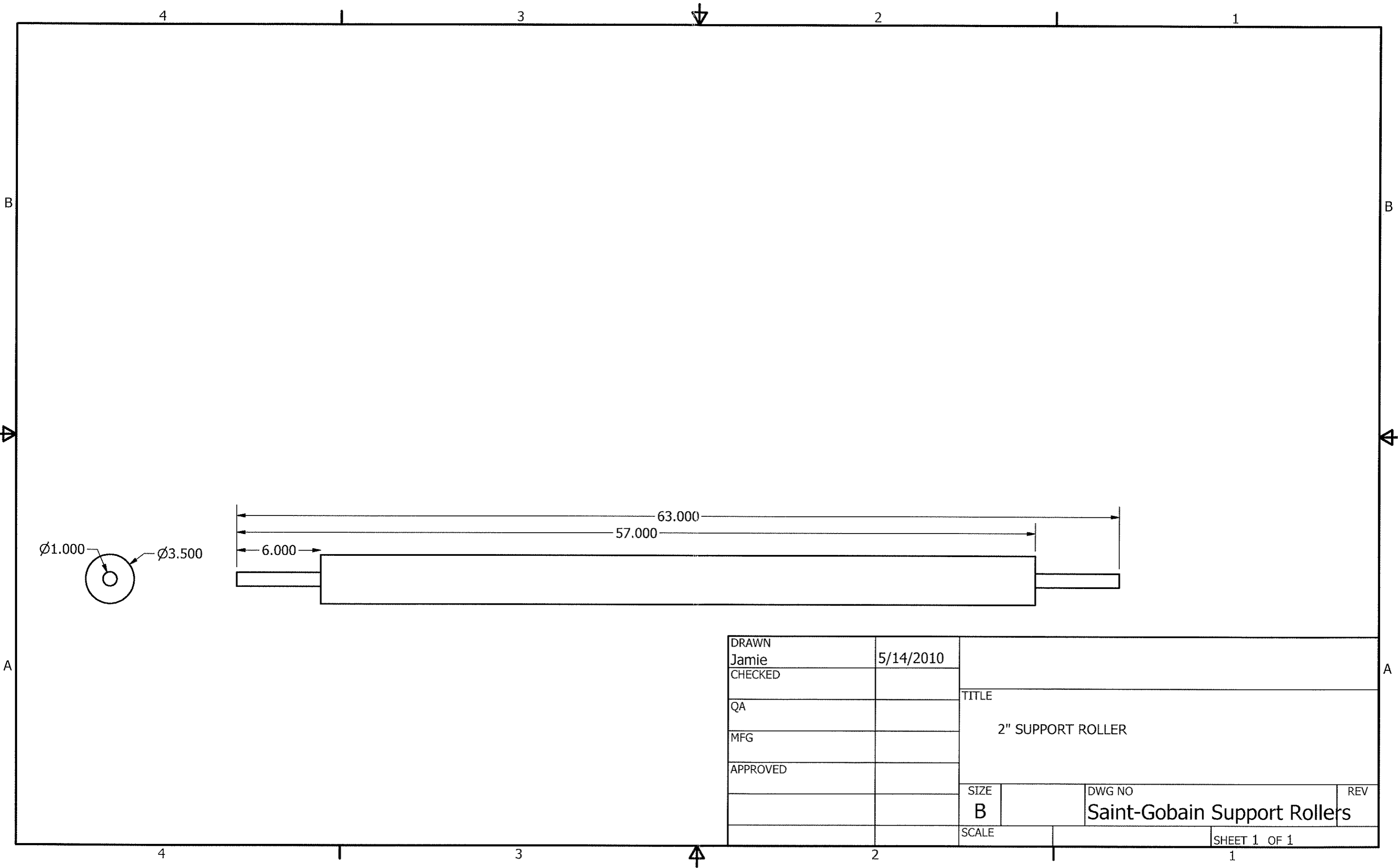

| | | | | |
|----------|-------|-----------|----------------------------|-------------------------------------|
| DRAWN | Jamie | 5/14/2010 | TITLE 2" SUPPORT ROLLER | |
| CHECKED | | | | |
| QA | | | | |
| MFG | | | | |
| APPROVED | | | SIZE | DWG NO |
| | | | B | Saint-Gobain Support Rollers |
| | | | SCALE | REV |
| | | | | SHEET 1 OF 1 |

4 3 2 1

B

B

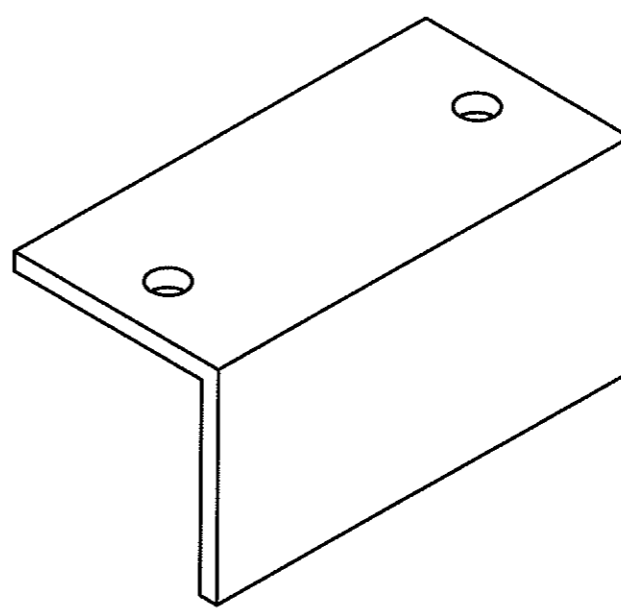
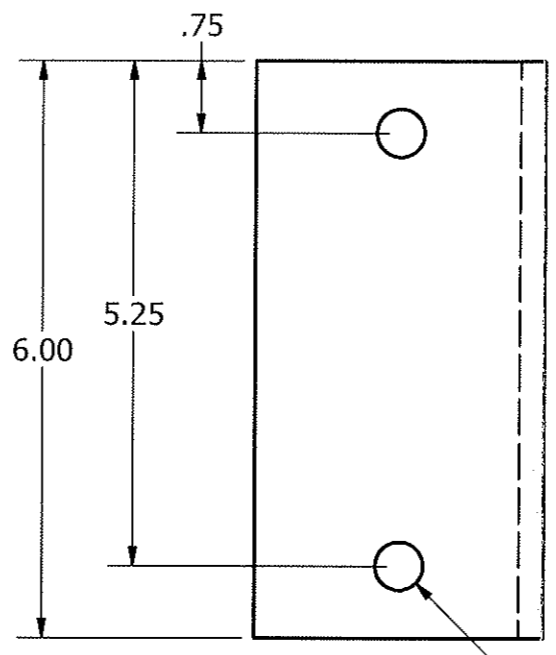

Ø.50X2

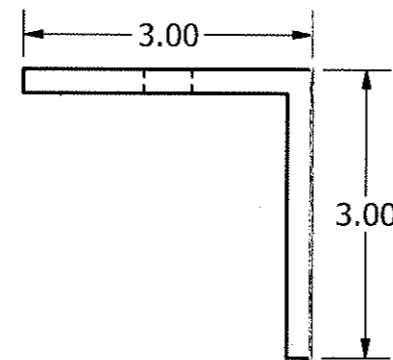
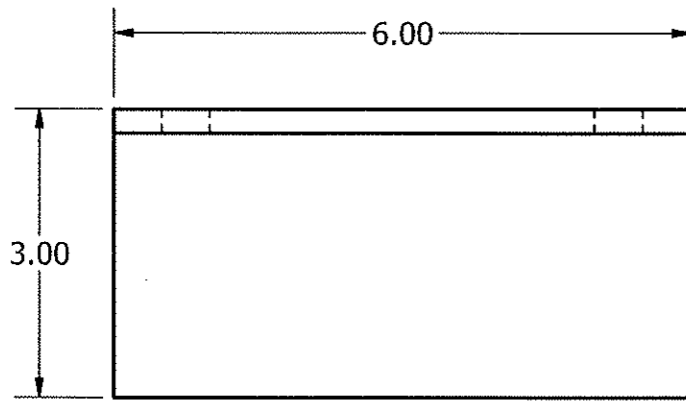

A

A

A

A

| | | | | |
|----------|-------|-----------|---|-----------------------------|
| DRAWN | Jamie | 5/14/2010 | | |
| CHECKED | | | | |
| QA | | | TITLE PILLOW BLOCK BUSHING ANGLE BRACKET | |
| MFG | | | 3" X 3" STEEL ANGLE | |
| APPROVED | | | | |
| | | | SIZE | DWG NO |
| | | | B | Saint-Gobain Angle Brackets |
| | | | SCALE | REV |
| | | | | |
| | | | SHEET 1 OF 1 | |

4 3 2 1

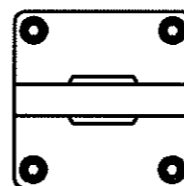
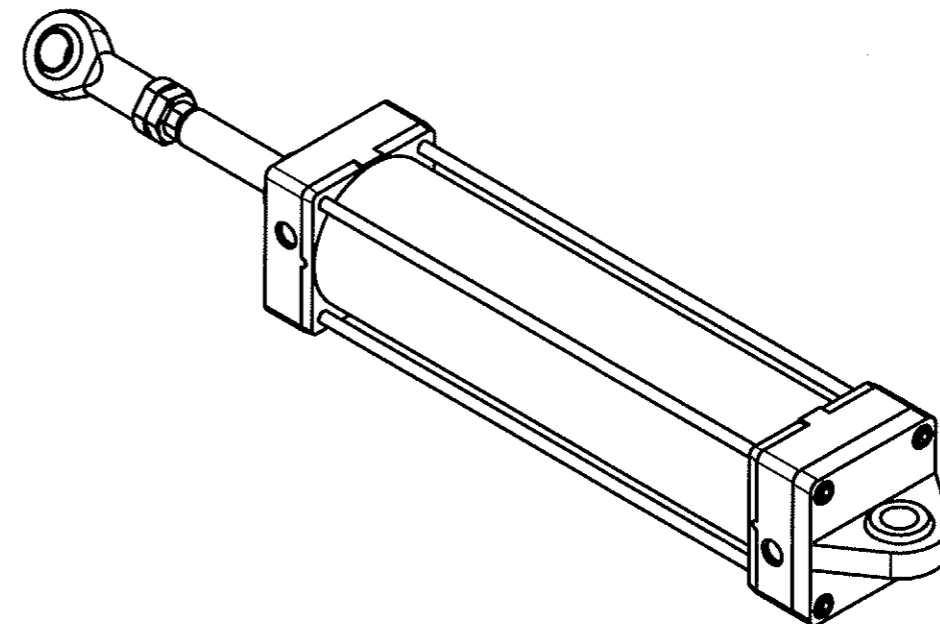
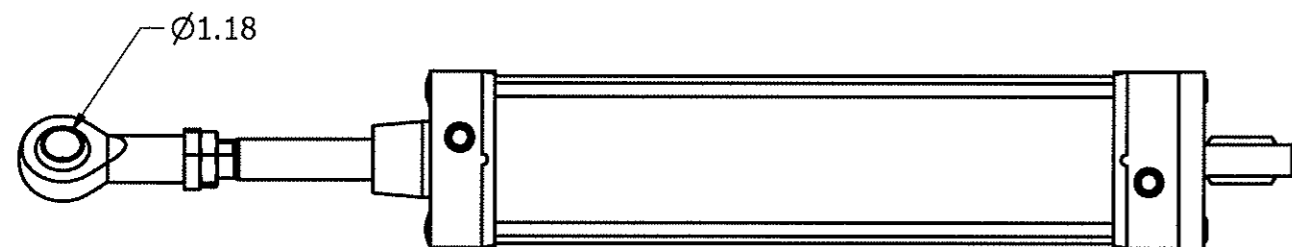
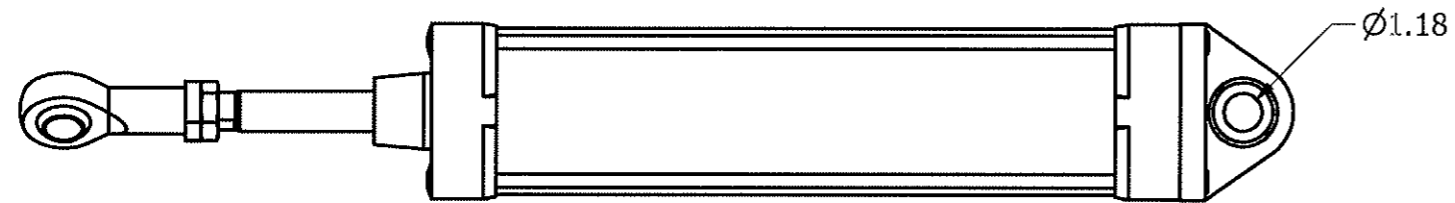

| | | | | |
|----------------|-----------|---|-------------------------------------|-----|
| DRAWN Jamie | 5/13/2010 | TITLE Milwaukee Air Cylinder PN: 1X50-61-210-7X17 | | |
| CHECKED | | | | |
| QA | | SIZE B | DWG NO Saint-Gobain Air Cylinder | REV |
| MFG | | SCALE | | |
| APPROVED | | SHEET 1 OF 1 | | |

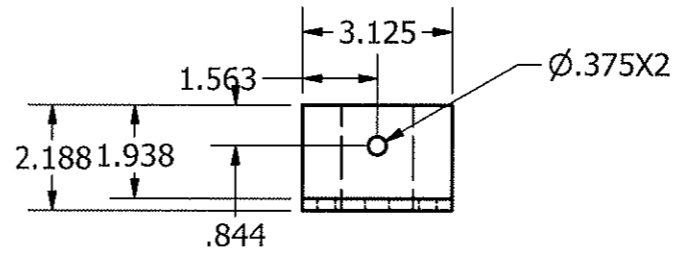
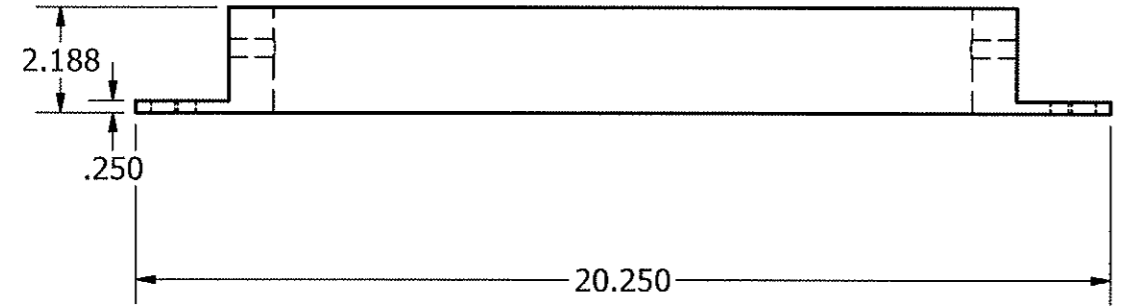
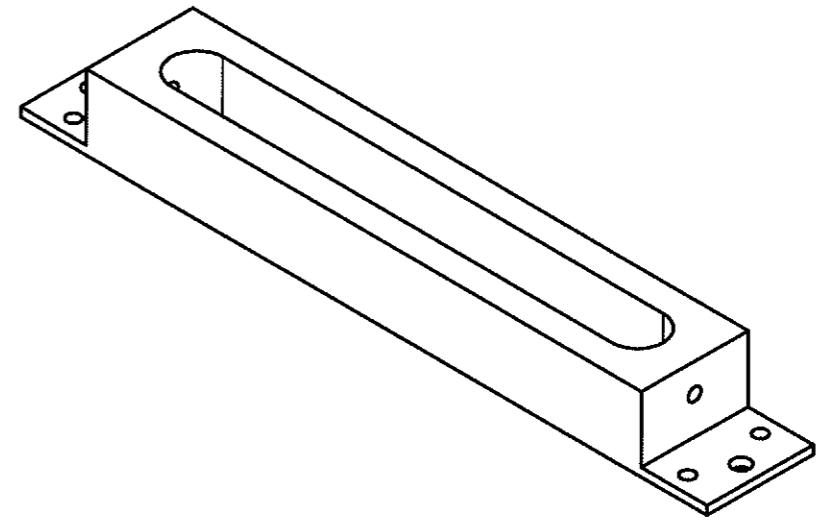
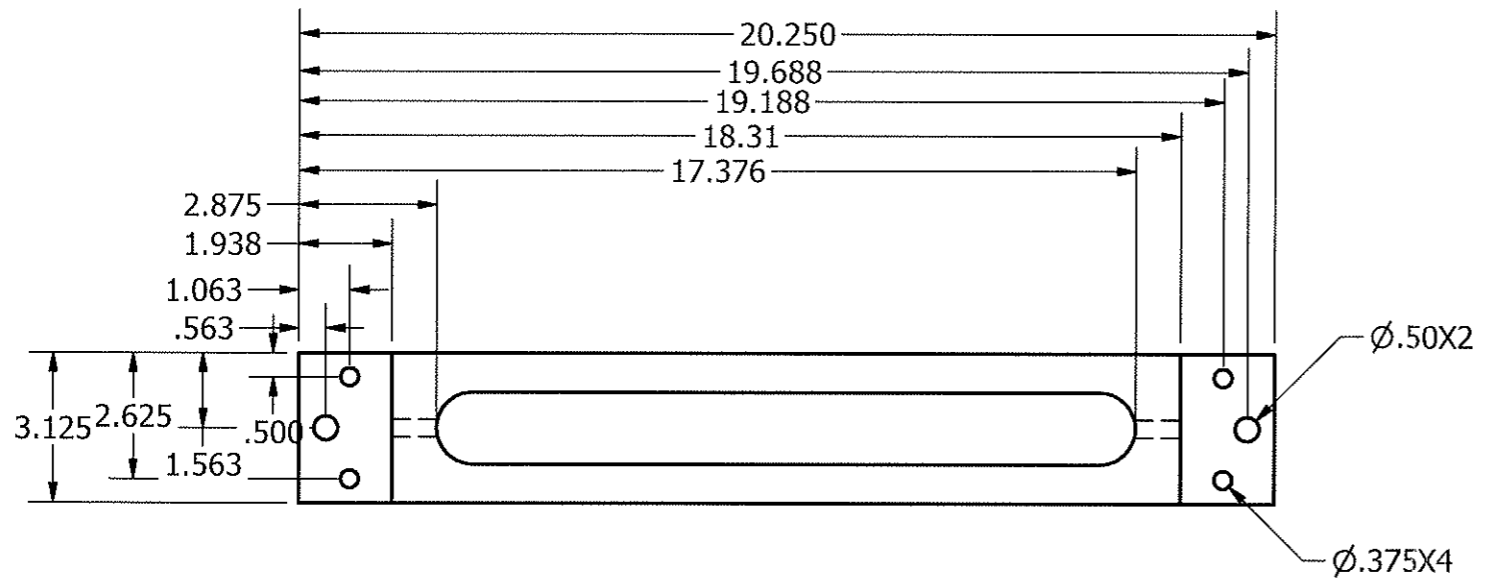

| | | | | |
|----------|-------|-----------|--------------------------------------|-----------------------------------|
| DRAWN | Jamie | 5/14/2010 | | |
| CHECKED | | | | |
| QA | | | TITLE | |
| MFG | | | BOSTON GEAR TAKE UP FRAME | |
| APPROVED | | | CATALOG #: TU1828-6 ITEM CODE: 29830 | |
| | | | SIZE | DWG NO |
| | | | B | Saint-Gobain Boston Block Adjustr |
| | | | SCALE | REV |
| | | | | SHEET 1 OF 1 |

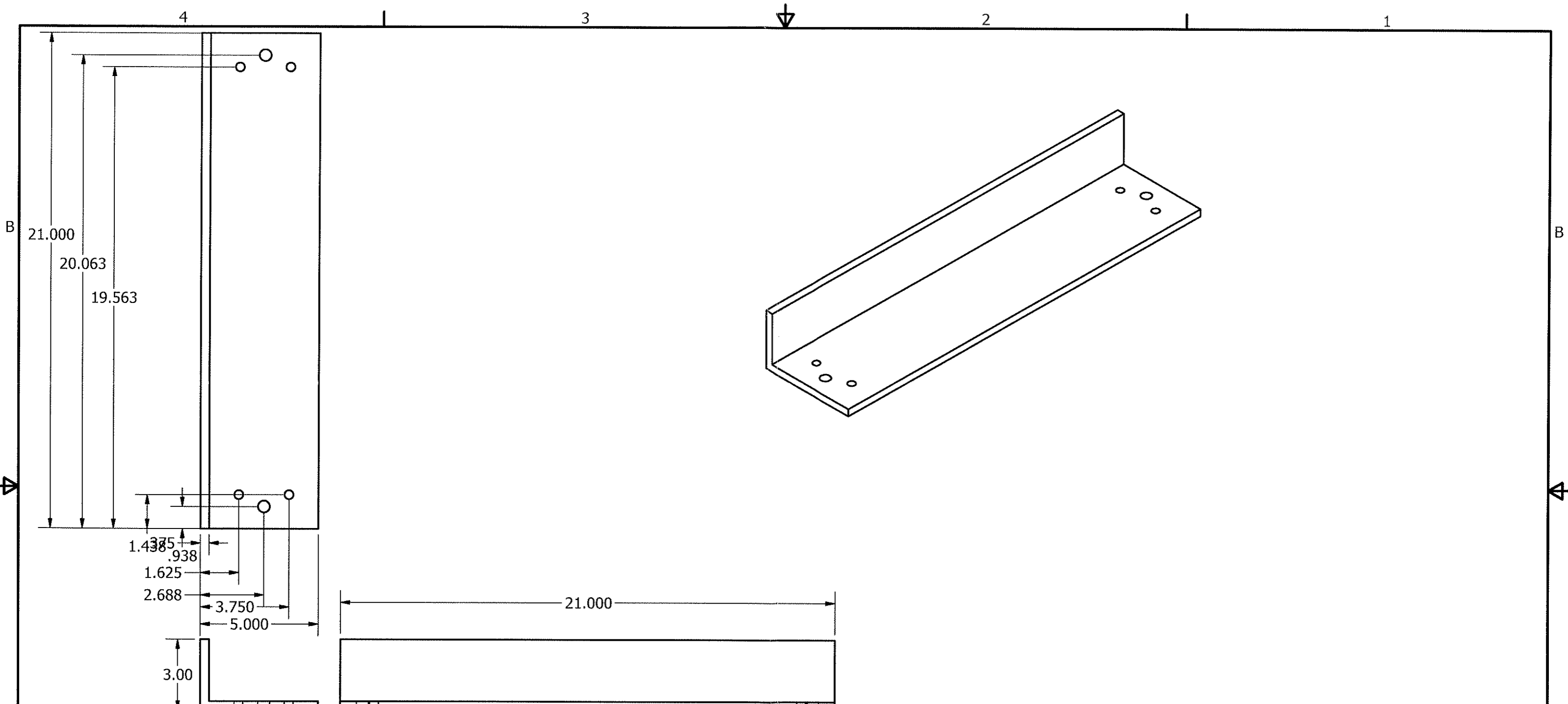

| | | | |
|----------------|-----------|---|--|
| DRAWN Jamie | 5/14/2010 | TITLE TAKE UP FRAME MOUNTING BRACKET | |
| CHECKED | | | |
| QA | | SIZE B | |
| MFG | | | |
| APPROVED | | DWG NO Saint-Gobain Boston Block Adjustr | |
| | | REV | |
| SCALE | | SHEET 1 OF 1 | |

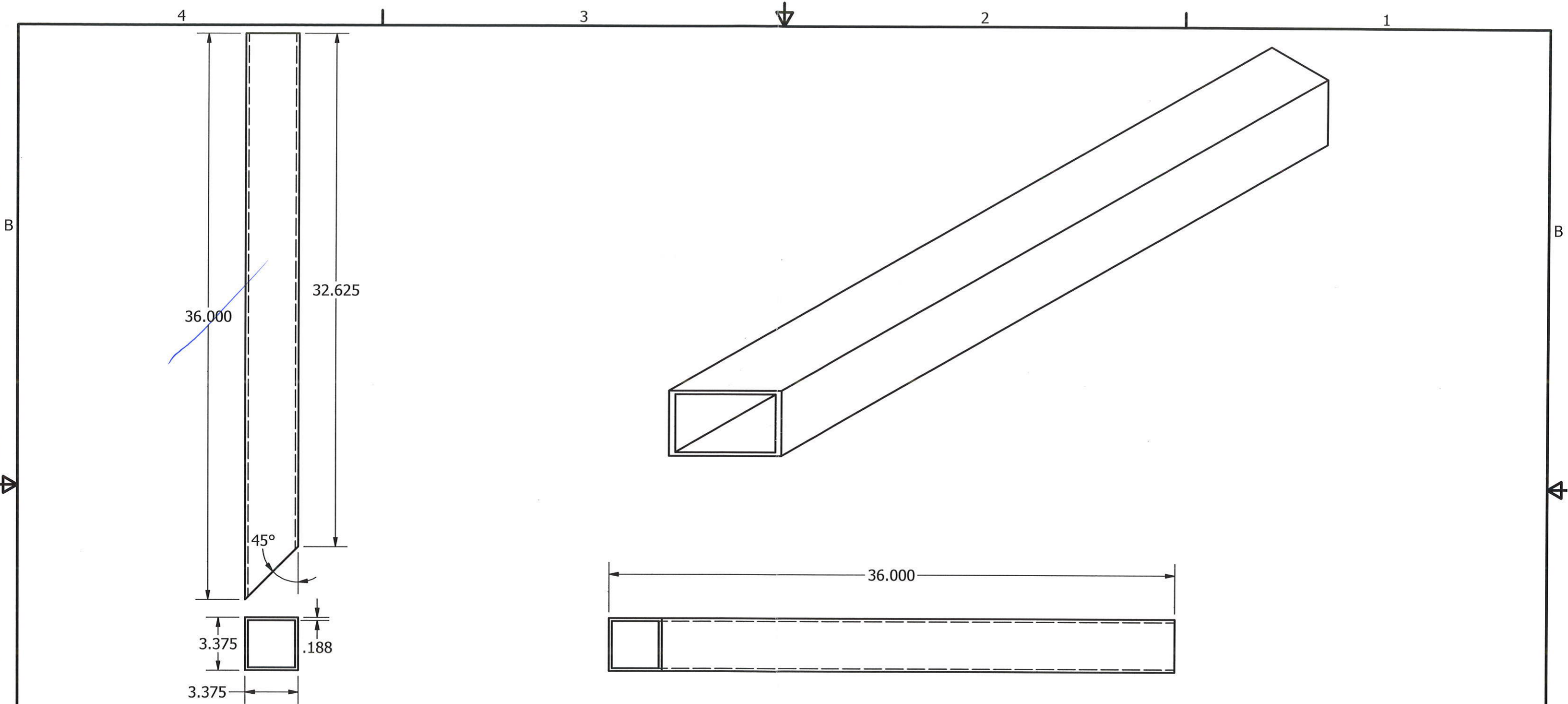

| | | | | |
|----------|-------|-----------|-------------------------------------|---------------------------------|
| DRAWN | Jamie | 5/14/2010 | TITLE | |
| CHECKED | | | OUTER SUPPORT TUBE | |
| QA | | | 3 3/8" X 3 3/8" X 3/16" SQUARE TUBE | |
| MFG | | | SIZE | DWG NO |
| APPROVED | | | B | Saint-Gobain Gearbox Support Tu |
| | | | SCALE | REV |
| | | | | SHEET 1 OF 1 |

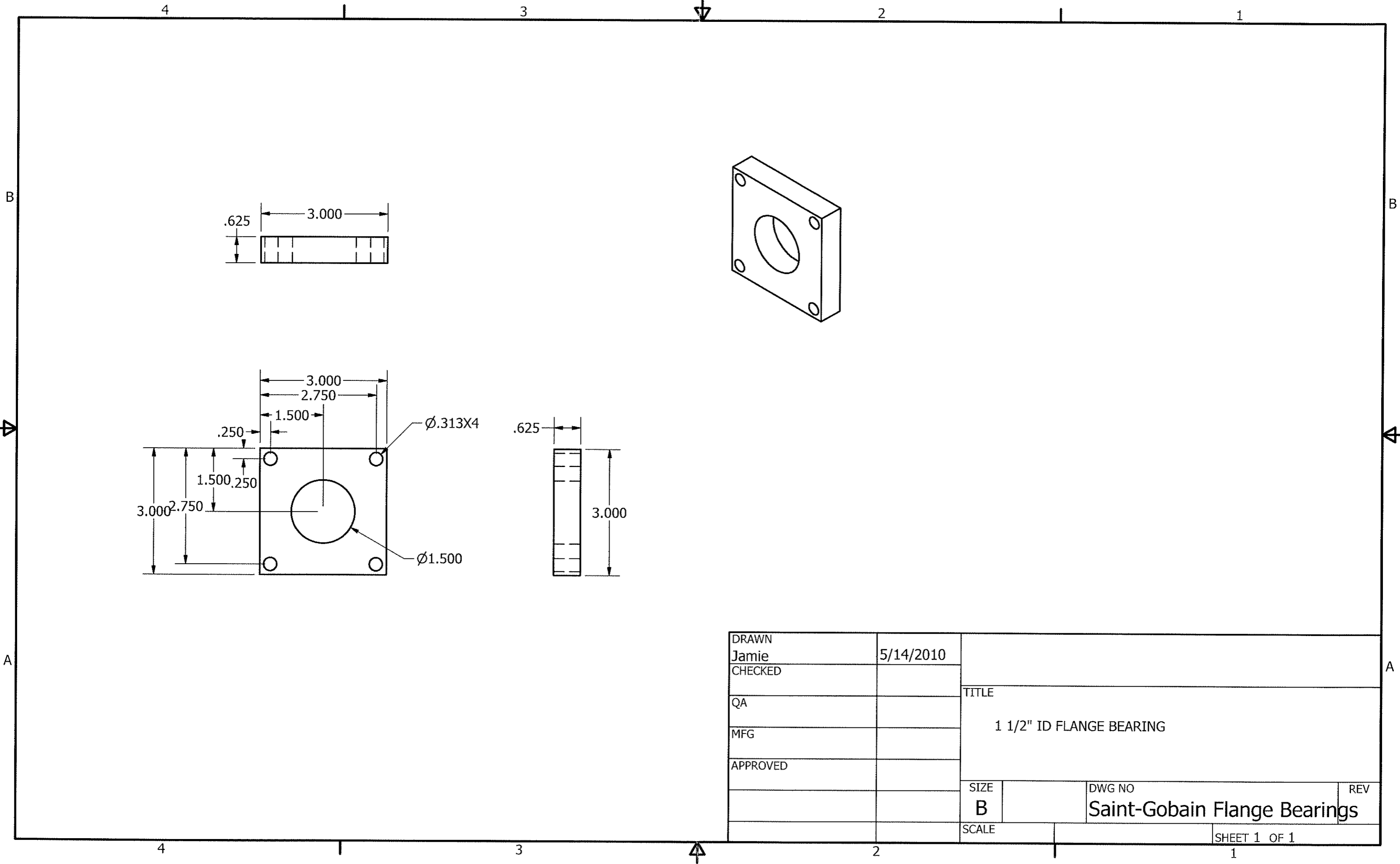

| | | | | |
|----------|-------|-----------|-------------------------------------|--------------|
| DRAWN | Jamie | 5/14/2010 | TITLE 1 1/2" ID FLANGE BEARING | |
| CHECKED | | | | |
| QA | | | | |
| MFG | | | SIZE B | |
| APPROVED | | | | |
| | | | DWG NO | REV |
| | | | Saint-Gobain Flange Bearings | |
| | | | SCALE | SHEET 1 OF 1 |

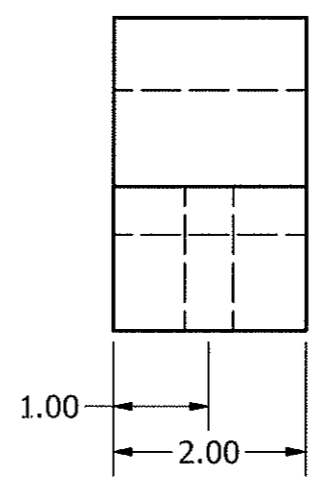
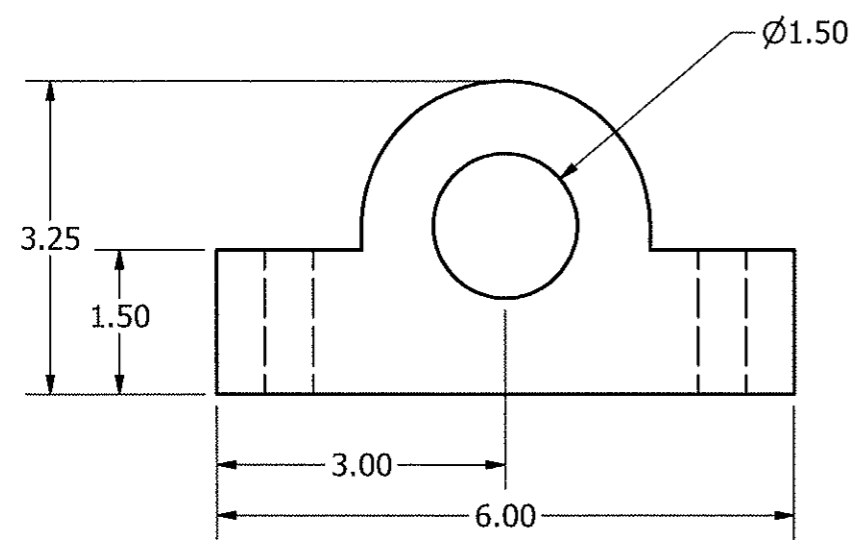
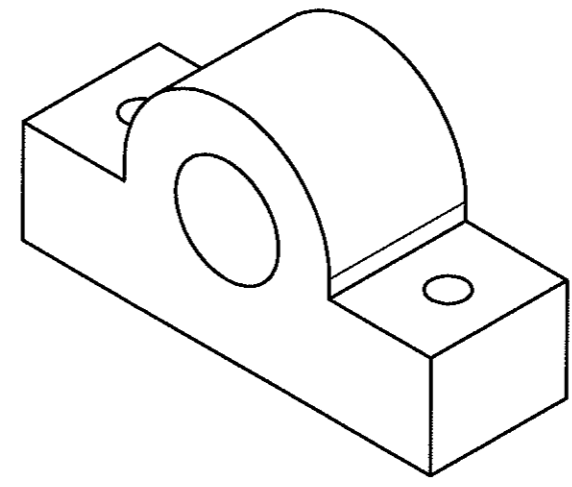
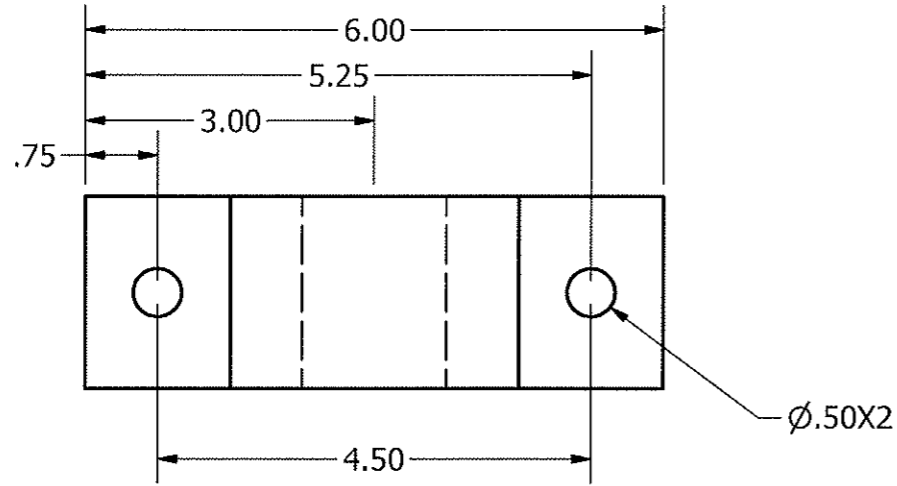

| | | | | | |
|----------|-------|-----------|--|----------------------------|-----|
| DRAWN | Jamie | 5/13/2010 | TITLE | | |
| CHECKED | | | | | |
| QA | | | <h1 style="text-align: center;">Pillowblock Bushing</h1> | | |
| MFG | | | | | |
| APPROVED | | | | | |
| | | | SIZE | DWG NO | REV |
| | | | B | Pillowblock Bushing | |
| | | | SCALE | SHEET 1 OF 1 | |

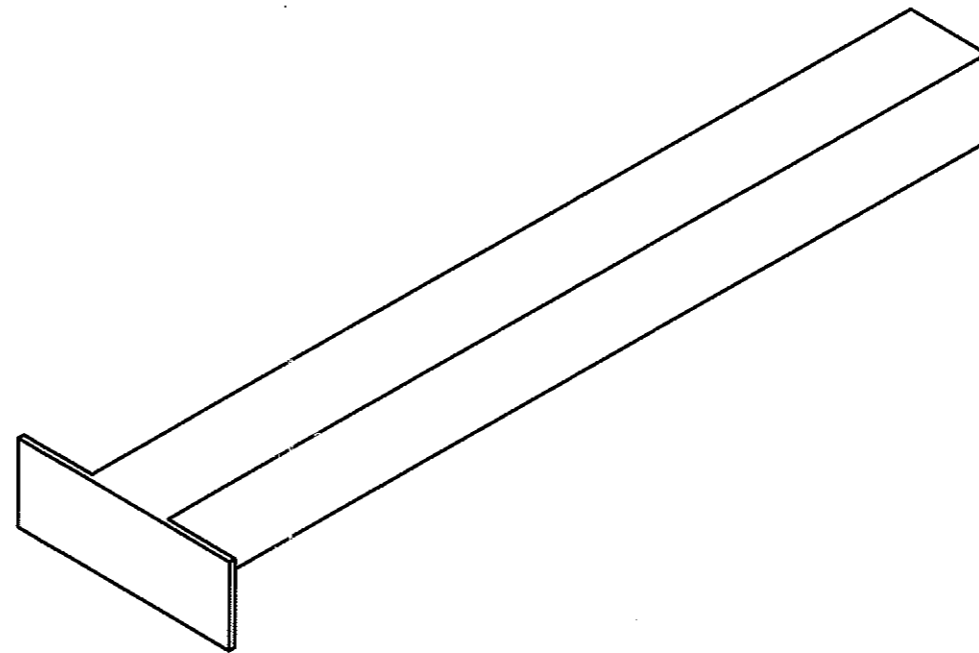
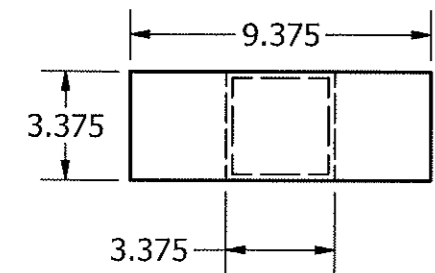
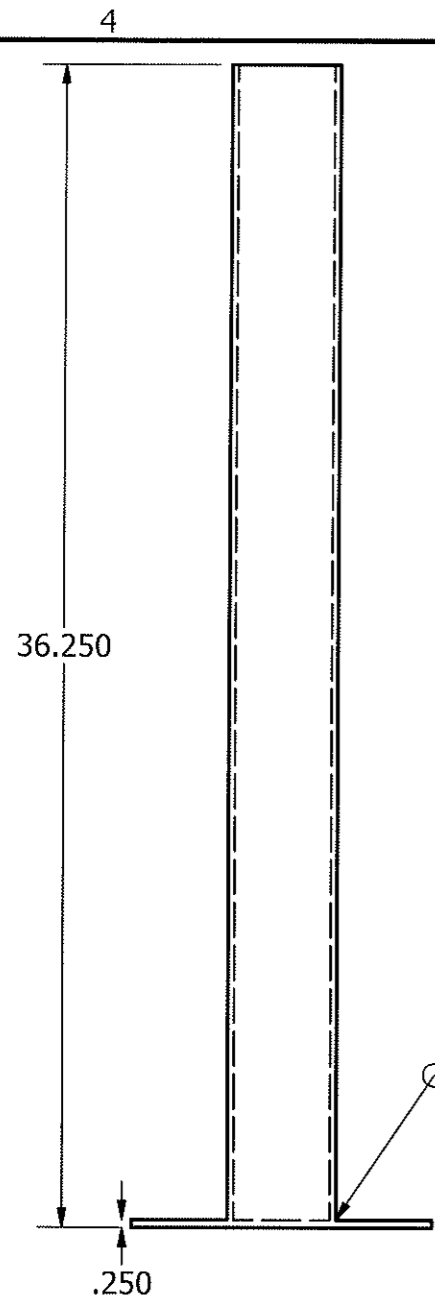

| | | | | |
|----------------|-----------|---|---|-----|
| DRAWN Jamie | 5/14/2010 | TITLE OUTER SUPPORT TUBE: PILLOWBLOCK 3 3/8" X 3 3/8" X 3/16" SQUARE TUBE W/ 1/4" PLATE | | |
| CHECKED | | | | |
| QA | | | | |
| MFG | | | | |
| APPROVED | | SIZE B | DWG NO Saint-Gobain Outer Support Tube | REV |
| | | SCALE | SHEET 1 OF 1 | |

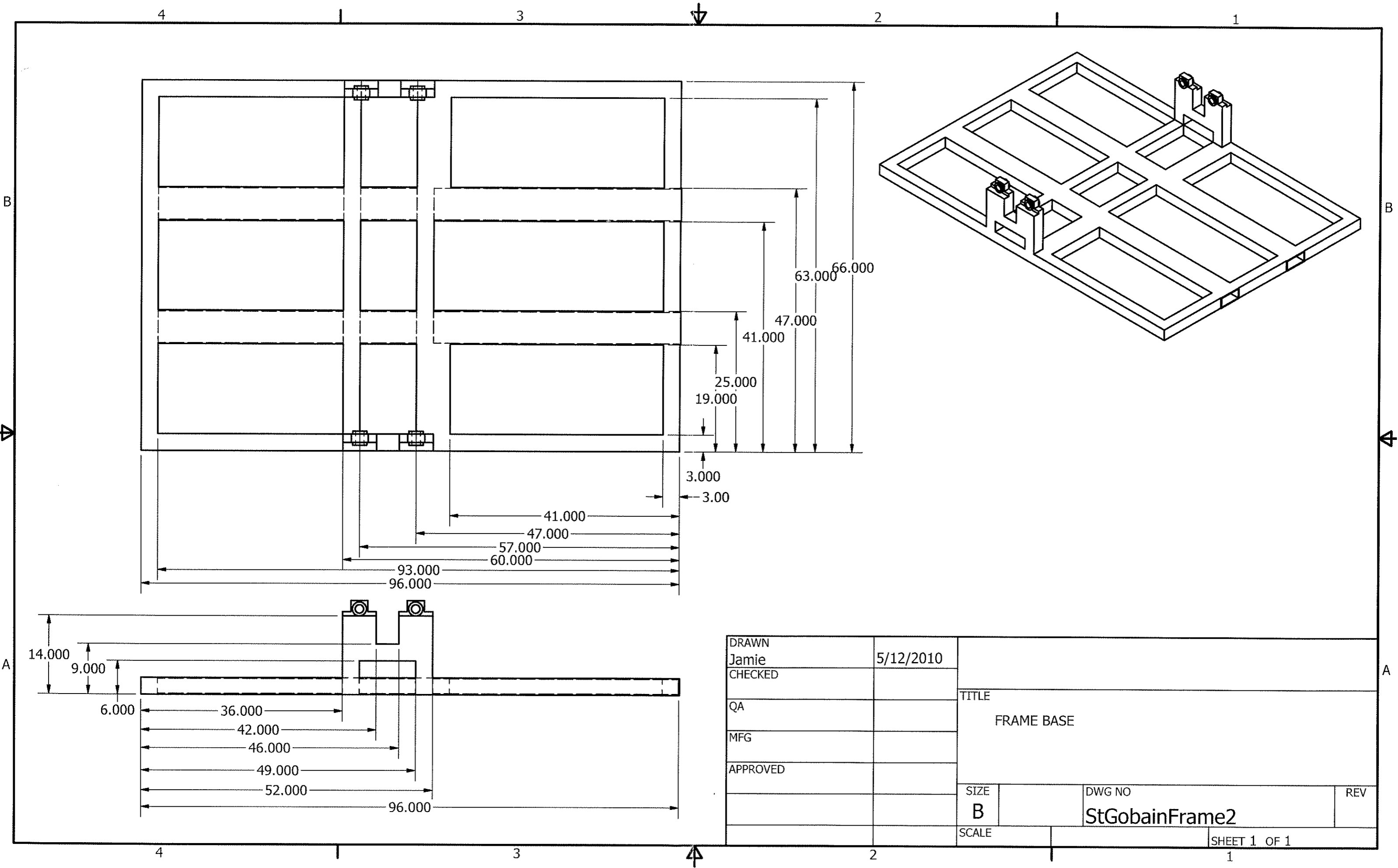

| | | | | |
|---------|----------|--------------|----------------|-----|
| DRAWN | Jamie | 5/12/2010 | TITLE | |
| CHECKED | QA | | FRAME BASE | |
| | MFG | | | |
| | APPROVED | | | |
| SIZE | B | DWG NO | StGobainFrame2 | REV |
| SCALE | | SHEET 1 OF 1 | | |