

Fibergrate Stair Tread Trimmer

Project lead:

Charles Elkins

Members:

Marcos Gonzales

Grant Morgan

Cory Land

Submitted for partial fulfillment of requirements for IT 495 senior projects class

Engineering Technology Department

Tarleton State University

Friday, April 30, 2010

Project Acceptance Page

Fibergrate Stair Tread Trimmer

Project Members

Charles Elkins

Marcos Gonzales

Grant Morgan

Cory Land

The following affirm that the project deliverables meets the needs of our customer and was accomplished by the project team:

Industrial Sponsor:

Joel Hush Production-Manager 5-11-10
Name and Title Date

Faculty Mentor:

George Muller 5-10-10
Name and Title Date

Department Approval:

George Muller 5-10-10
Name and Title Date

Project Leader:

Charles Elkins 5-10-10
Name and Title Date

Table of Contents

Project Acceptance Page..... 2

Table of Contents 3

Executive Summary 4

Business Case..... 4

Current Process..... 4

Project Scope and Goals 5

Business Need 7

Project Scope and Goals 8

Project Strategy..... 9

Recommendations 10

Deliverables..... 10

Project Cost 11

Return on Investment 12

Executive Summary

Business Case

Over the past several years, Fibergrate Composite Structures has ramped up its stair tread cover production. With the increased production, Fibergrate has come to realize that there is much room to cut cost with all of the excessive handling and extra steps involved in the stair tread cover trimming procedure. After conducting some time studies, Fibergrate feels that they are taking an overly excessive amount of man hours to get the job done.

Current Process

When inventories fall to a set level or a large order comes in for stair treads, production begins in the hand layup section of manufacturing. Hand layup will produce 10-20 stair treads from raw resin and fiberglass. In this first step the stair treads are unfinished and about 12 feet long and 20-24 inches wide depending on the mold used. Once a batch is completed the unfinished covers are moved via forklift to the fabrication building. At this point a worker carefully cuts the cover down the middle with the large crosscut panel saw. This saw is equipped with pneumatic clamps but they are not well suited for holding the stair tread cover in place. This results in a few rejects due to out of alignment cuts. If the stair tread being ordered is smaller than the molded part there may be two additional cuts by the panel saw required to get it to the correct size. This adds two more opportunities of error and the creation of more rejected parts. Now the ends are trimmed off with two more cuts. Once the part is finished being trimmed on the panel saw it is placed on a rack and moved to the EMA shaper. The shaper has already been modified with a platform to allow for trimming of the stair treads toe and fitted with a 7.25" diamond grit blade. The platform supports the grating while the toe is cut and fed through by means of a HolzHer power stock feeder. Once this cut is completed the stair tread cover

is placed back on the rack. At this point the approximately 12 foot long tread covers can be placed in inventor to fill orders or may be cut to lengths between 1 and 3 feet to fill an order. **The purpose of this project is to modify the EMA shaper and Holz Her power feeder to facilitate an additional vertical cut through the stair tread cover to reduce production handling time by at least half. Then improve the Dust collection of the EMA shaper.**

Project Scope

Senior Design Team, consisting of Tarleton State Engineering Technology students Charles Elkins, Marcos Gonzales, Cory Land, and Grant Morgan have been contracted by Fibergrate Composite Structures to analyze their current stair tread cover trimming operations and to provide decision support tools that will assist in developing optimized procedures for the stair tread cover trimming process. While this optimization will be the main priority of this project, the support tool will also reveal how specific changes will impact several other parameters of the stair tread cover trimming process

Project Goals

The objective of this project is to identify major time consuming steps in the stair tread cover trimming process and see if some can either be combined or eliminated. Our goal is to reduce handling of material as well as the overall time it takes to trim the stair tread covers to the desired length as well as procure a more consistent (within tolerance) method to trim the stair tread covers

Business Need

Current State

Fibergrate Composite Structures Inc. is a global manufacturer of fiberglass reinforced plastic (FRP) products for industrial and recreational use. Their products range from square mesh grating, structural shapes, and stair tread covers. It is in the process of cutting stair tread covers that the fabrication department at Fibergrate Composite Structures Inc. is operating inefficiently. Unfortunately, due to the nature of the FRP products, Fibergrate Composite Structures Inc. must rely heavily on equipment designed for the woodworking industry to conduct finishing operations on its products. The result is a very tedious and manual operation that translates into higher cycle times for stair tread trimming processes. The higher cycle times in turn result in a more expensive operation and a frustrated work force. The team will concentrate on improving the stair tread trimming processes. Fibergrate Composite Structures Inc. has provided specific “pain points” that should be given special consideration, but every process will be thoroughly analyzed to determine a more efficient way of completing the tasks, with the ultimate goal of reducing cycle times in all areas of the stair tread trimming process. After carefully reviewing a time-motion study provided by Fibergrate Composite Structures Inc. , it is clear that special attention will be given to the “generic” process, as this is the area that utilizes the most time.

The scope of this project encompasses only the stair tread cutting portion of manufacturing. Currently, Fibergrate Composite Structures Inc. does not have a model in place to simulate its stair tread cutting portion of the manufacturing processes. Senior Design Team wishes to modify the current equipment, to allow Fibergrate Composite Structures Inc. to easily trim the stair tread cover product with reduced operations and handling time. The effects on handling and production time by any changes considered can then be compared with the status quo. The value of optimizing this quantity is to minimize the handling and cutting times, yet still is able to satisfy demand and safety.

The stair tread production line operates by passing product between two cutting operation on two separate pieces of equipment. The raw stair tread is spilt in to two 12” wide by 12’ lengths on the large cross cut

saw. Then the nose is trimmed on the shaper. Then the product goes back to the cross cut saw and is trimmed to the appropriate length for the order. Due to this approach, there are multiple handling steps that can be eliminated if the nose trimming machine was also capable of the materials depth. Our team developed a new saw head and dust collection system that can be added to the current nose trimmer. The cad models created are based on Fibergrate Composite Structures Inc. current equipment and the modifications we developed.

When completed, the modified stair tread cutting machine will be able to cut the nose of the stair tread and also split the raw product simultaneously thus reducing handling and processing time. Easily updatable Autodesk Inventor CAD models of the entire stair tread machine and the new saw head will be supplied.

Project Scope and Goals

Senior Design Team, consists of Tarleton State Engineering Technology Students and has been contracted by Fibergrate Composite Structures Inc. to analyze their current stair tread cutting operations and to provide a method of cutting that reduces operation steps and time. While the cutting operations are the main focus of the project, we will also look at improving the dust collection of the machine.

The objective of the project is to identify a cost effective, small foot print machine that can quickly and efficiently conduct trimming operations on stair treads. Our goal is to reduce the handling and production time by 50% while also reducing tool wear and improve dust collection. These recommendations will reduce costly part rejections, lead time in filling orders, as well as reducing labor and handling time.

Project Outline

Fibergrate has requested that the senior projects team work in unison with their personnel to develop a unique solution to the problems associated with the stair tread cover cutter. Fibergrate has specified that the main goal is to improve the productivity of the stair tread cover cutter, specifically in making the process quicker with less material handling.

Fibergrate Composite structures has provided several “Pain points” to address:

- The Holz Her power feeder’s slowest setting is 15 feet per second which is too fast for most of the operations being preformed.
- Current dust collection method is ineffective.
- The multiple manual operations translate into high cycle times due to product being transferred repeatedly between two machines.

To address their concerns we utilized Autodesk inventor to draft the concept in a manner that allowed quick design and analysis of the modification. This allowed the team to adapt their ideas as until the concept became a producible design that met the specifications of Fibergrate. Using stress analysis and other analyzing tools, the team was able to accurately test their design for certain criteria that must be met before a final design was decided upon. With basic time studies completed the team was able to determine the best method replace the current system. The team also examined the current dust collection system of the shaper and by comparing it to the methods on other equipment and was able to determine a better solution. After examining the current machine we were able to redesign the current manual process to reduce the transfer between machines that is needed to complete the product. With the proposed in hand, Fibergrate should be able to improve the profit margin on stair tread covers.

Recommendations

We propose that Fibergrate Composite Structures Inc. modify their current, proven, equipment in such a way that it can make two cuts simultaneously. Unfortunately the current power feeder does not feed the

product slow enough for two simultaneous cuts. The current power feeder moves product at a rate of 15 feet per minute. We recommend purchasing a new 1hp three phase power feeder that is capable of feed rates from 6 feet per minute to 15 feet per minute. This would allow for lower loads on the cutting blades and should extend blade life while also improving tolerances. The slower power feeder will also improve several process operations performed by this machine that are not in the scope of this project but can also be resolved by replacing the feeder with a new one.

We recommend increasing the diameter of the dust collection duct from three inches to six inches. The current duct does not allow for adequate air flow and thus does not collect much dust. Also the addition of a dust collection box or shields will also greatly improve the dust collection from the machine. The newly added saw has its own dust shield and requires an additional three inch duct/tube for the collection of dust from the new saw.

Once these changes are made product flow should to the EMA for two saw passes first. Then the product should move to the cross cut saw and cut to the desired length. This should reduce the handling steps and processing time by more than half.

- Modify the current stair tread trimming equipment to accept a second cutting head.
- This modification would not take up extra manufacturing space.
- A larger duct in combination with a dust shield will greatly improve the dust collection of the saw.
- Change product flow to EMA shaper for two passes then to the cross cut saw to be cut to length.

Deliverables

Fibergrate Composite Structures Inc. will receive the following:

- Detailed working drawings including vendor item specific numbers.
- A series of recommendation for dust collection improvements.
- Parts list.
- A thorough report that will have detailed information, including a basic return on investment analysis of the impact of the changes recommended and the potential benefits they could generate.

Project CostFibergrate Stair Tread Trimmer
parts list

Item number	Description	Quantity	Price	Shipping	Total Price	Source
6204K185	Cast Iron V-Belt Pulley 3.55" OD, 1" Bore	1	\$15.40		\$15.40	McMaster-Carr
6204K353	Cast Iron V-Belt Pulley 6.45" OD, 5/8" Bore	1	\$25.46		\$25.46	McMaster-Carr
8350T69	Hardened Precision Shaft 1" OD, 7-1/4" Overall Length, 5/8"-11 Thread One End	1	\$40.92		\$40.92	McMaster-Carr
3760T219	Precision-Plus Steel Ball Bearing -- ABEC-1 DbI-Shielded Bearing for No. R16 for 1" Shaft Dia	2	\$31.00		\$62.00	McMaster-Carr
Model 20-480	4 WHEEL / 8 SPEED POWER FEEDER	1	\$1,049.99	\$150	\$1,149.99	http://www.redmondmachinery.com/browse.cfm/4,1706.html
5990K28	Base-Mount Single-Phase AC Motor NEMA 56y, Odp, Rigid Base, 3 hp, 3450 rpm	1	\$223.28		\$223.28	McMaster-Carr
56355K48	18" CLEAR FLEXIBLE DUCT HOSE 20ft. LENGTH	1	\$9.65		\$9.65	McMaster-Carr
8560K264	Acrylic Sheet 8'x48"	1	\$137.68		\$137.68	McMaster-Carr
	Roll of Duct Tape	2	\$5.00		\$10.00	Check Stock/ Walmart
	Misc Steel 0.25" and 0.5"	1	\$70.00		\$70.00	Check Stock
6061K604	Hardened Precision Steel Shaft 1" OD, 6" Length	1	\$7.91		\$7.91	McMaster-Carr
6435K18	One-Piece Clamp-on Shaft Collar Black-Oxide Steel, 1" Bore, 1-3/4" OD, 1/2" Width	2	\$3.04		\$6.08	McMaster-Carr
5825K777	2 CONVEYOR ROLLER SYSTEMS	2	\$212.90		\$425.80	McMaster-Carr
	30 MAN HOURS AT \$40/hr	30	\$40.00		\$1,200.00	
	UNFORSEEN COSTS, i.e. welding consumables, bolts, nuts, shipping, etc.	1	\$1,500.00		\$1,500.00	Check Stock
<u>TOTAL</u>					<u>\$4,384.17</u>	

Return on Investment

Our team believes that Fibergrate can see a return on investment for these modifications within one year. We came to this conclusion after looking at the estimated cut time for the panel saw to make a 12 foot cut in the 1/8" FRP panels that make up the stair tread covers. Each cut takes 3 to 5 minutes; we chose to calculate our ROI with the fastest possible cut time.

Total number of covers	1600
Parts per blade	24
Number of Blades	67
Cuts per part	7
Min per part	5
Cuts for 10 inch	5600
Cuts for 12 inch	4000
Average cuts per year	9600
With Changes	6400
Cuts saved*	3200
Hours saved**	160
<u>Cost saved at \$30/hr</u>	<u>\$4,800</u>

* Based on 800 10 inch and 800 12 inch parts being run each year

**Based on estimate of 3min per 12 foot cut on panel saw.

4

3

2

1

B

B

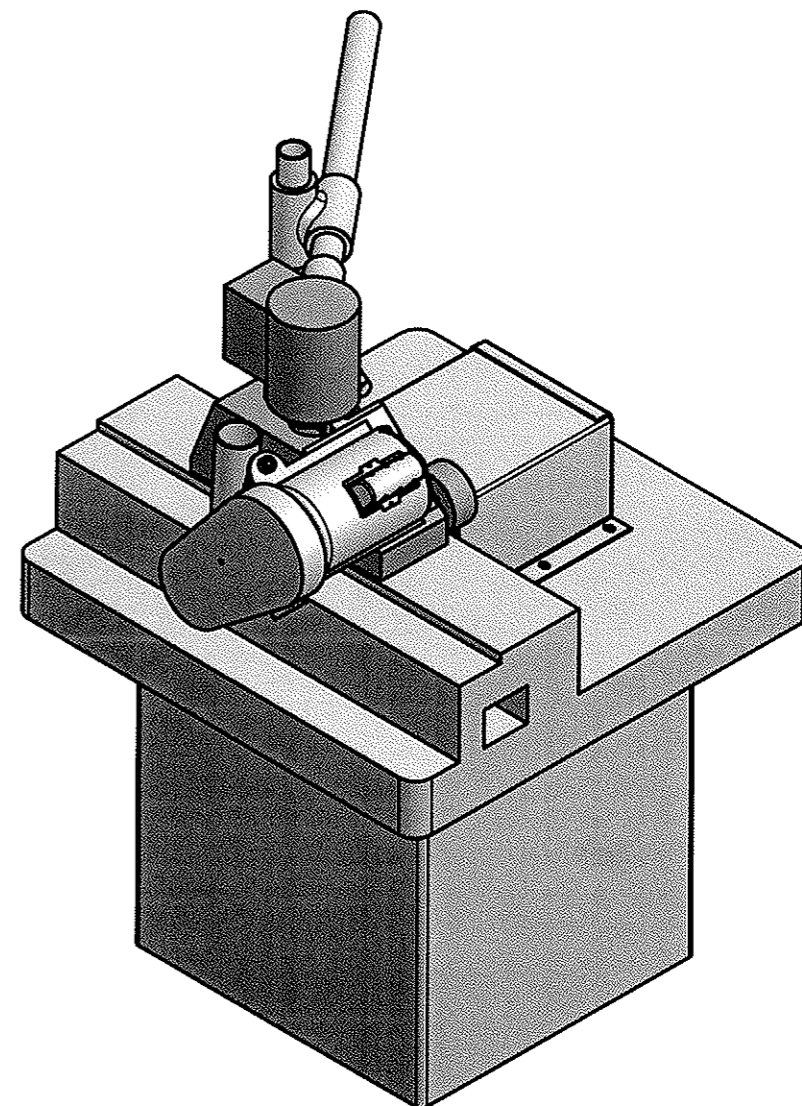
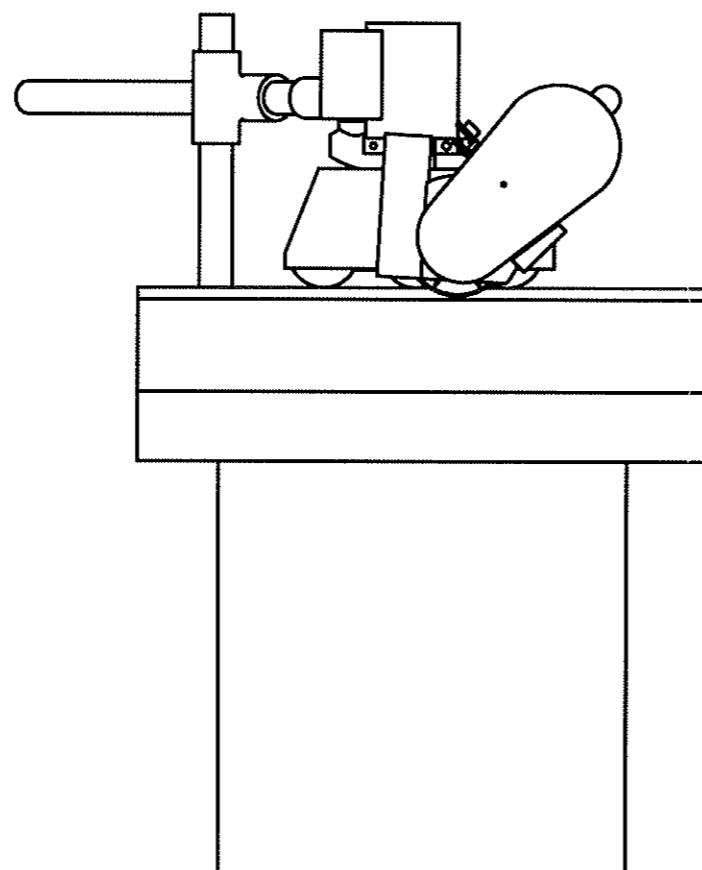
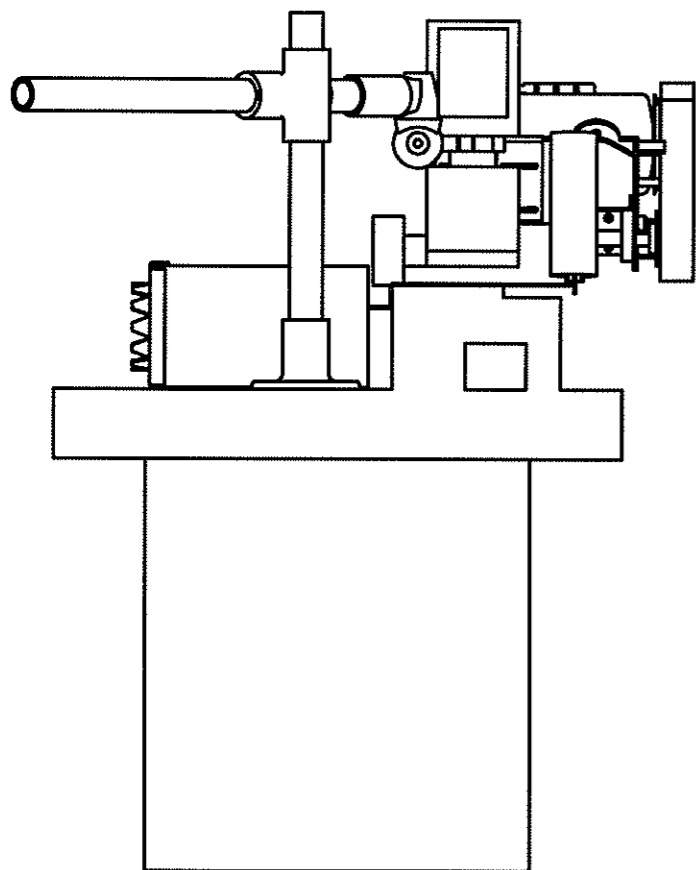

A

A

A

A

4

3

2

1

DRAWN	st_celkins	4/28/2010	TITLE STAIR TREAD TRIMMER		
CHECKED					
QA					
MFG					
APPROVED			SIZE	DWG NO	REV
			B	MasterDrawings	
			SCALE 0.08 : 1	SHEET 1 OF 10	

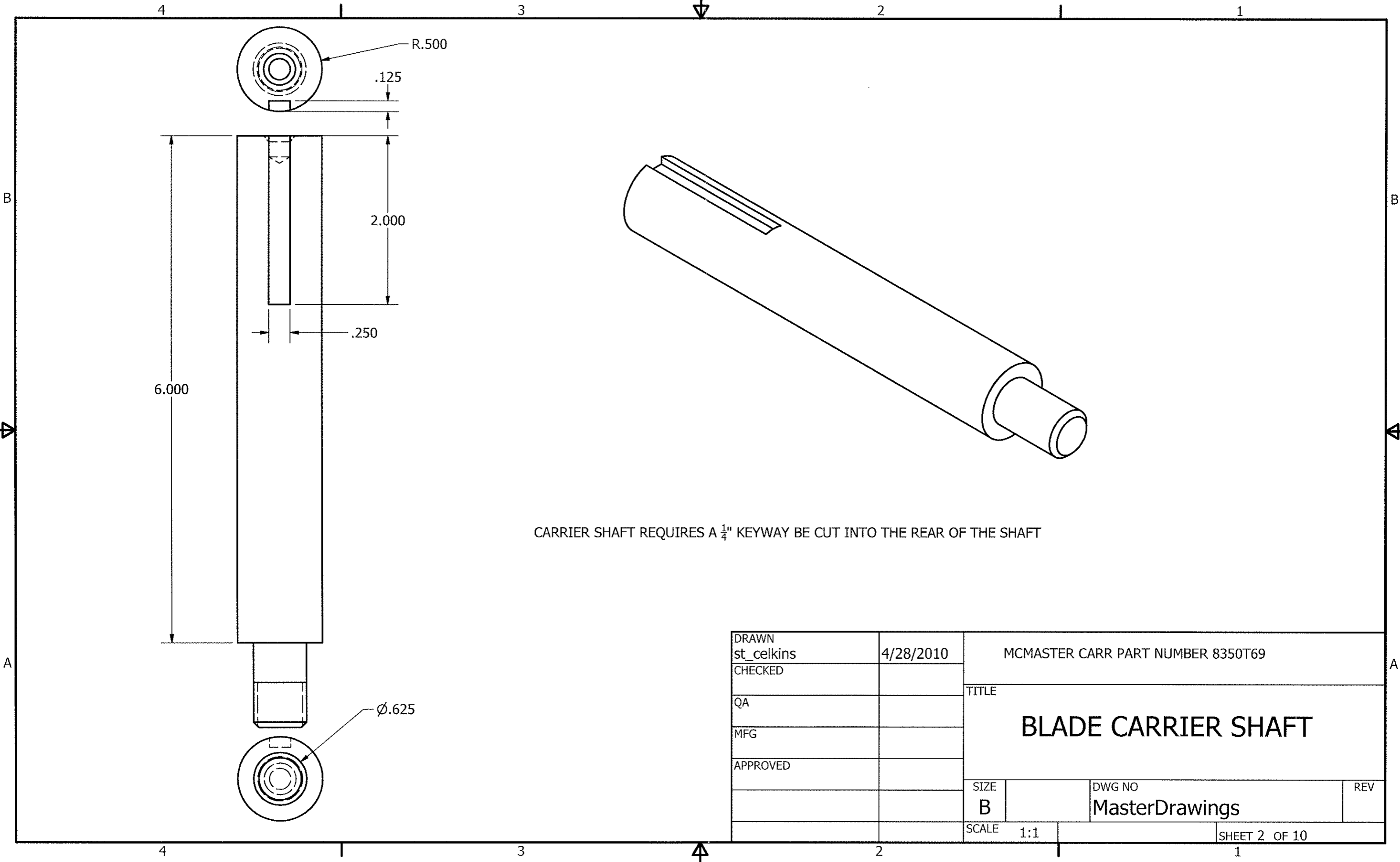

CARRIER SHAFT REQUIRES A 1/4" KEYWAY BE CUT INTO THE REAR OF THE SHAFT

DRAWN	4/28/2010	MCMASTER CARR PART NUMBER 8350T69		
st_celkins		TITLE		
CHECKED		BLADE CARRIER SHAFT		
QA		SIZE	DWG NO	REV
MFG		B	MasterDrawings	
APPROVED		SCALE	SHEET 2 OF 10	
		1:1		

4

3

2

1

B

B

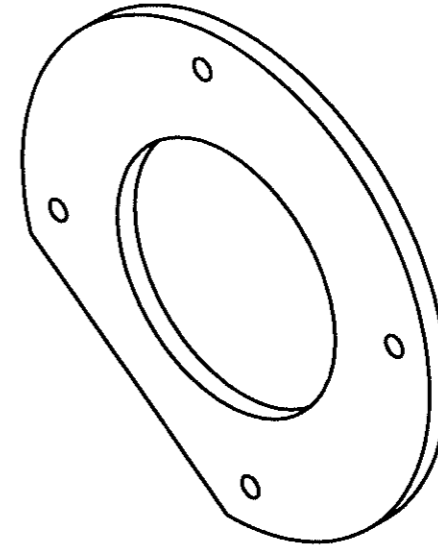
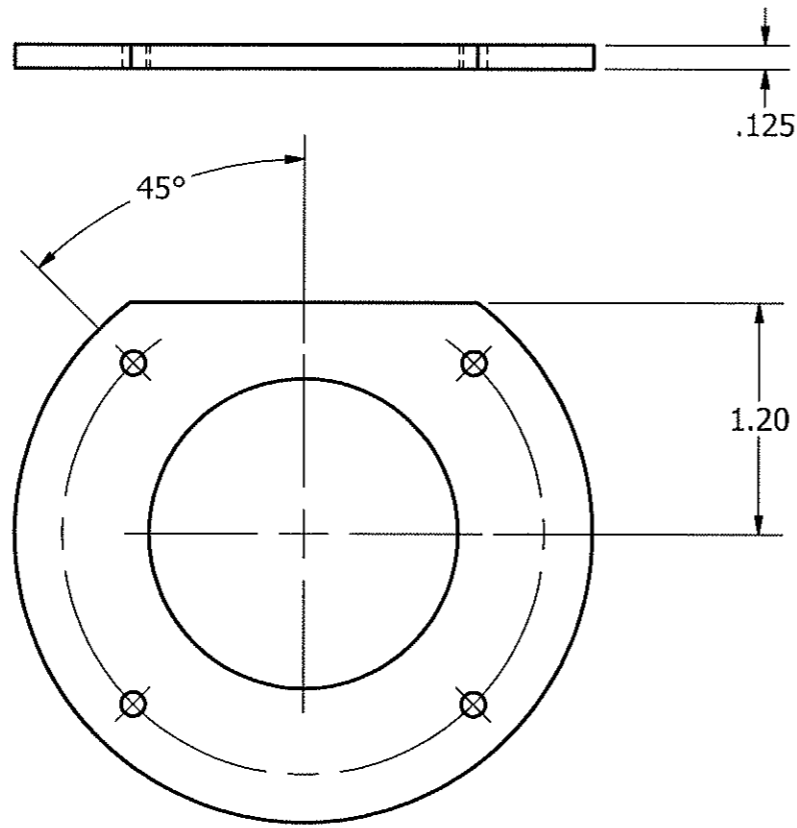

A

A

A

A

4

3

2

1

DRAWN	st_celkins	4/28/2010	TITLE BERING RETAINER PLATE 2X		
CHECKED					
QA					
MFG					
APPROVED			SIZE	DWG NO	REV
			B	MasterDrawings	
			SCALE	1:1	SHEET 3 OF 10

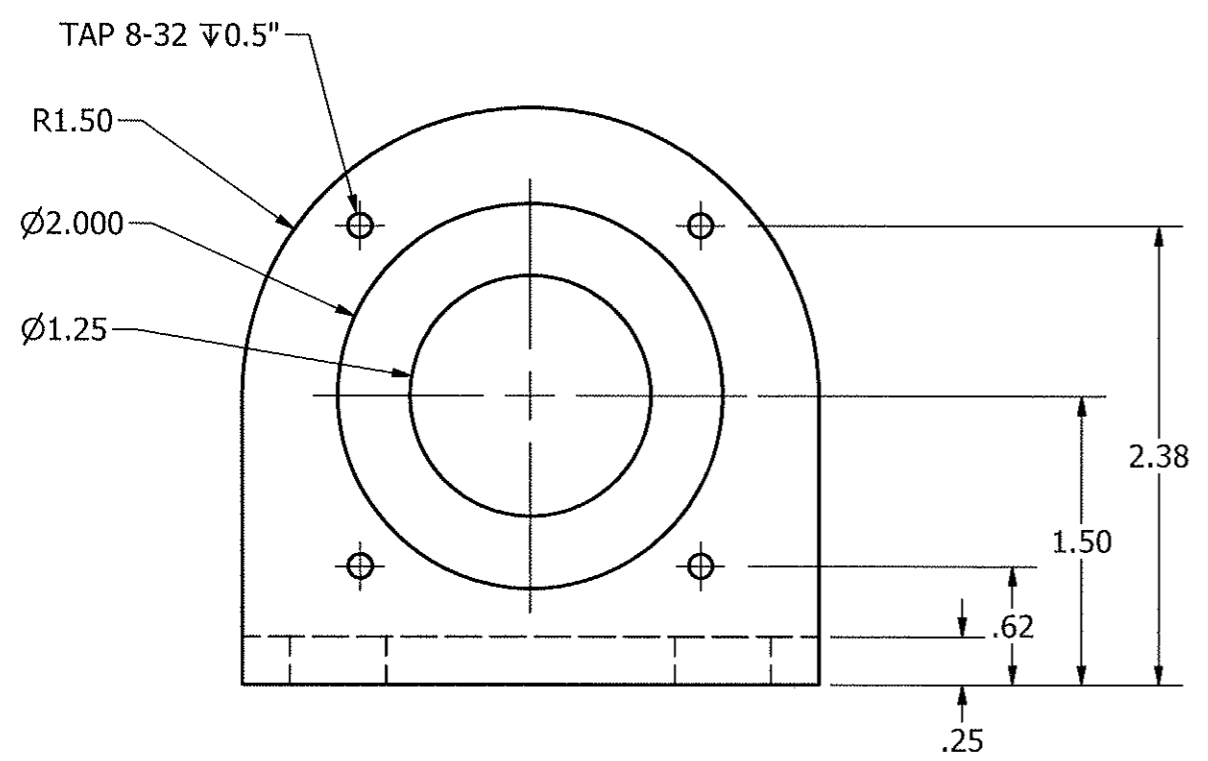
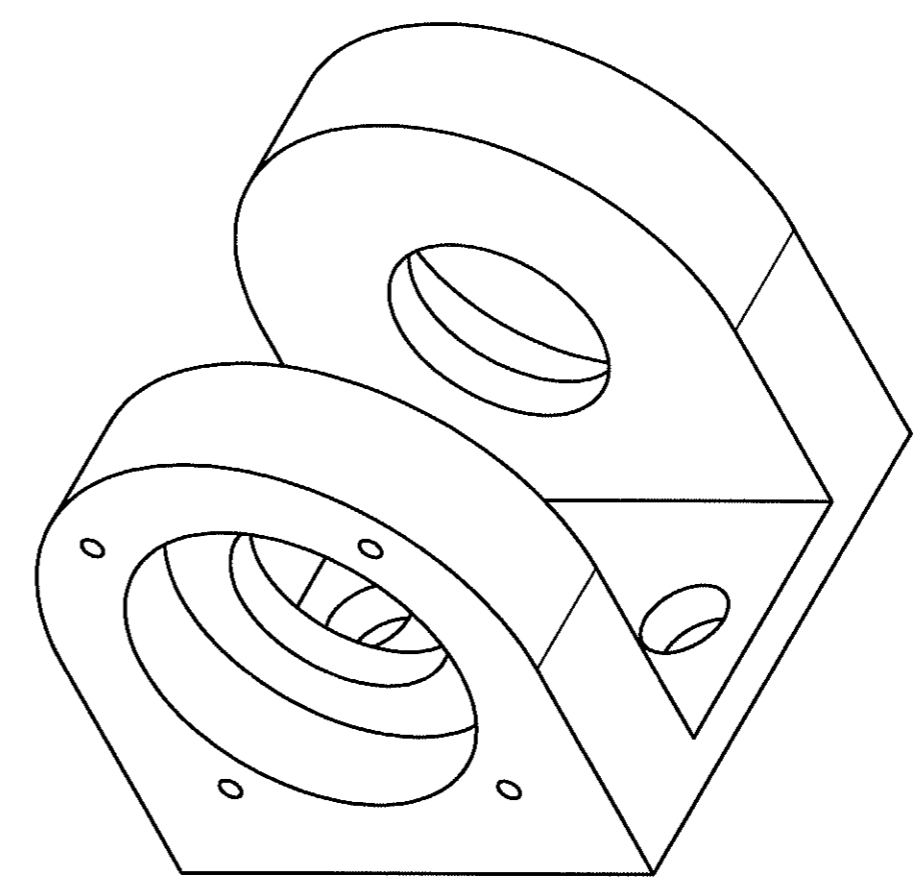
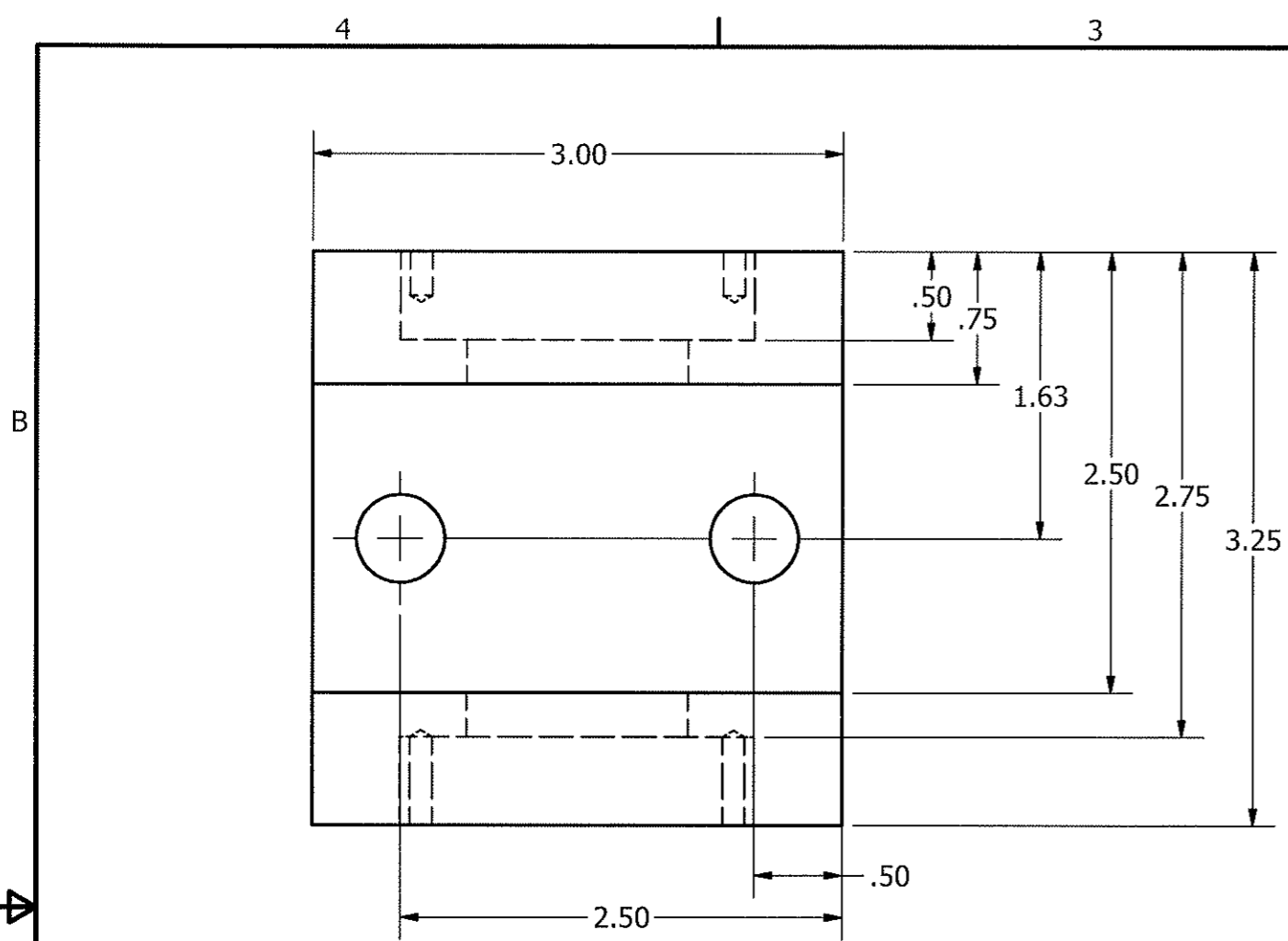

DRAWN	st_celkins	4/28/2010	TITLE		
CHECKED			BEARING CARRIER		
QA					
MFG					
APPROVED					
			SIZE	DWG NO	REV
			B	MasterDrawings	
			SCALE	SHEET 4 OF 10	
			1:1		

4 3 2 1

B

B

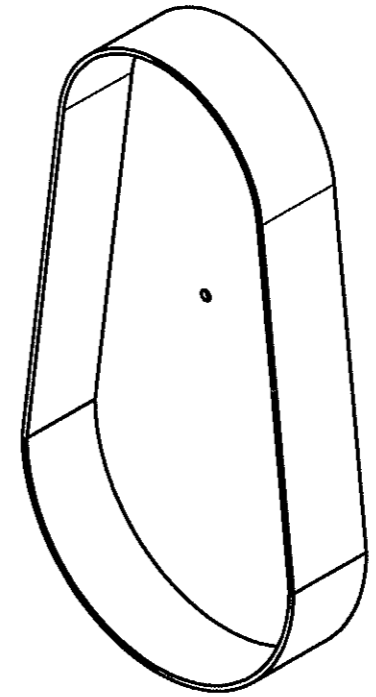
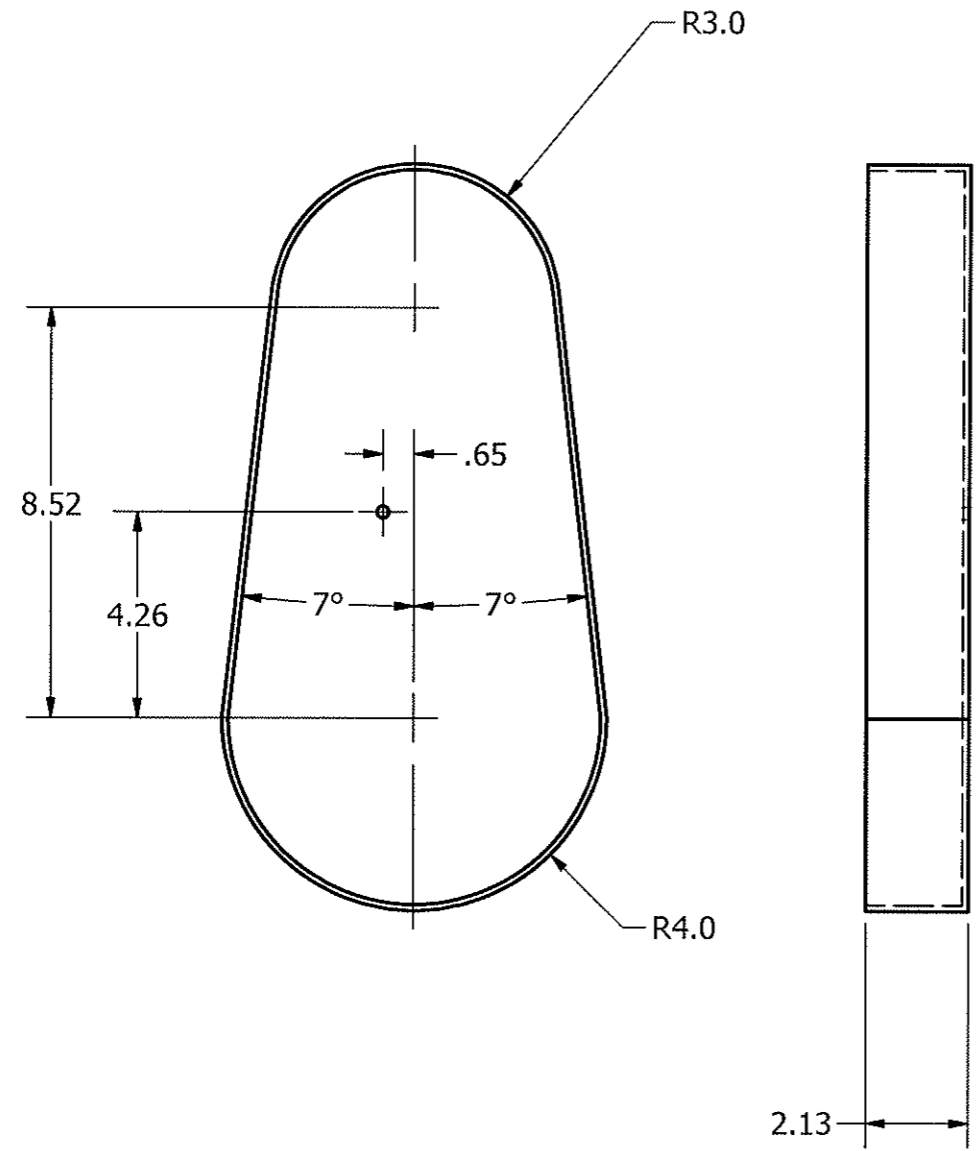

A

A

A

A

4 3 2 1

DRAWN	st_celkins	4/28/2010	TITLE BELT COVER		
CHECKED					
QA					
MFG					
APPROVED			SIZE	DWG NO	REV
			B	MasterDrawings	
			SCALE	4:1	SHEET 5 OF 10

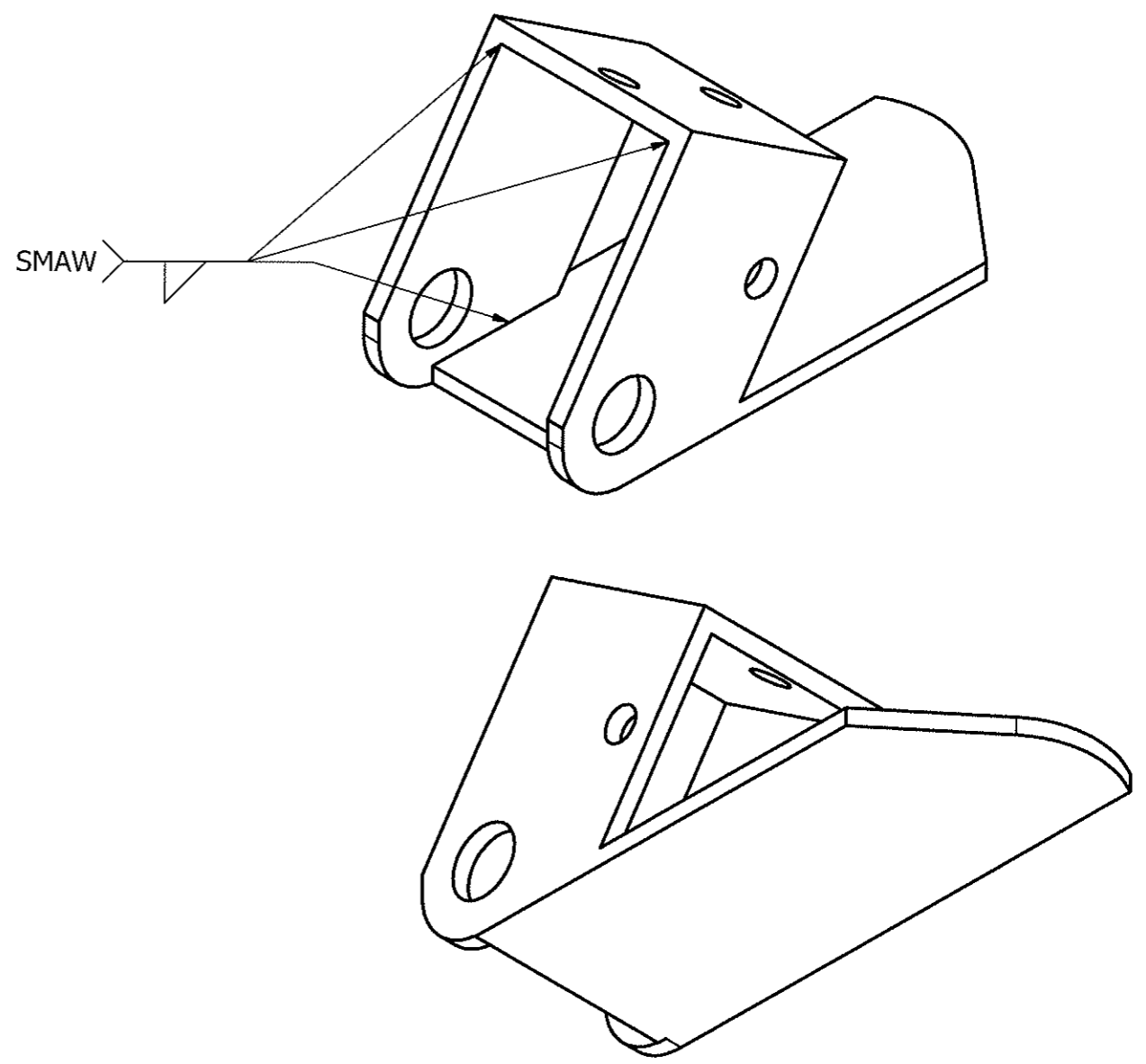
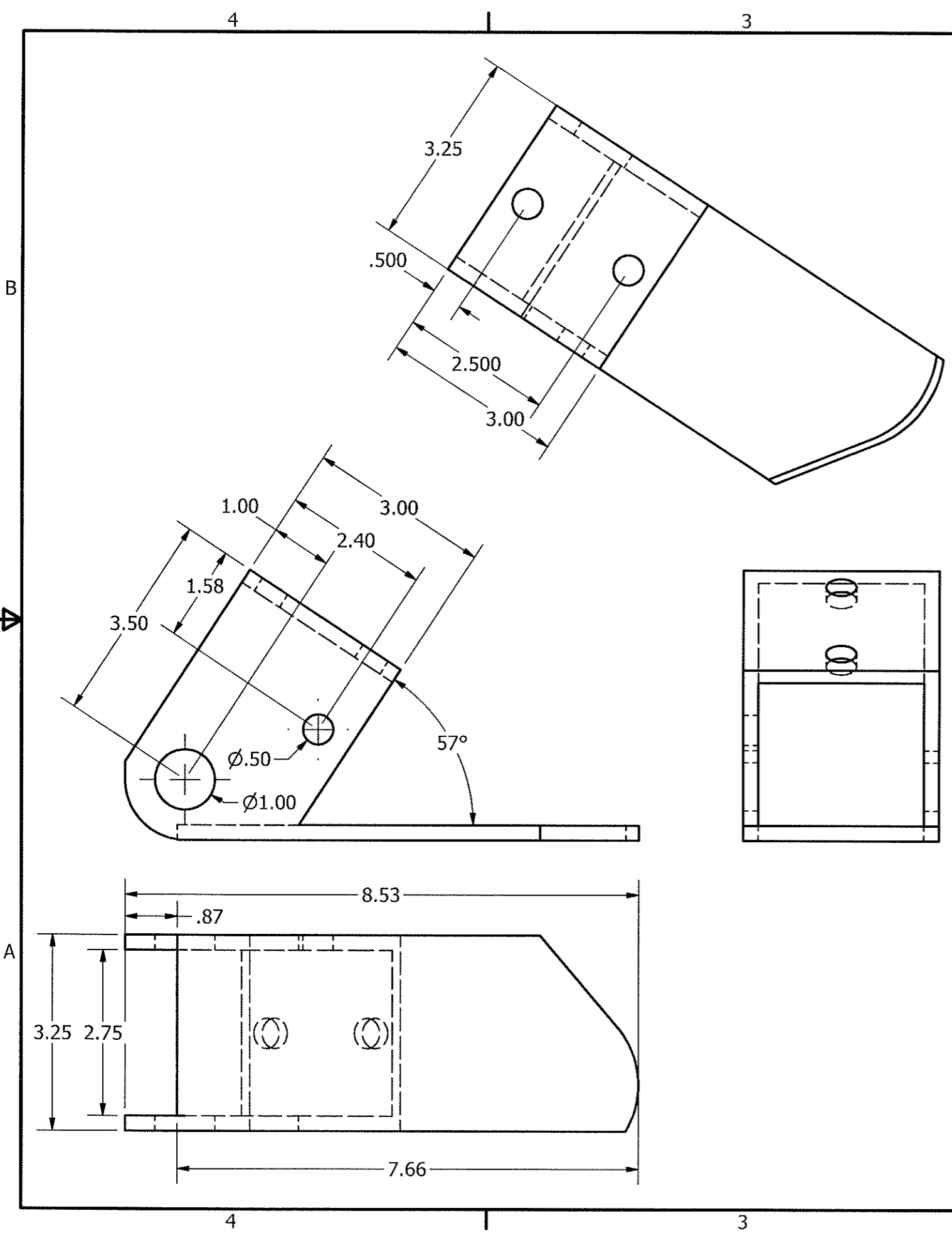

DRAWN	st_celkins	4/28/2010	TITLE BELT TENSENER BRACKET		
CHECKED					
QA					
MFG					
APPROVED			SIZE B	DWG NO MasterDrawings	REV
			SCALE 1:2	SHEET 6 OF 10	

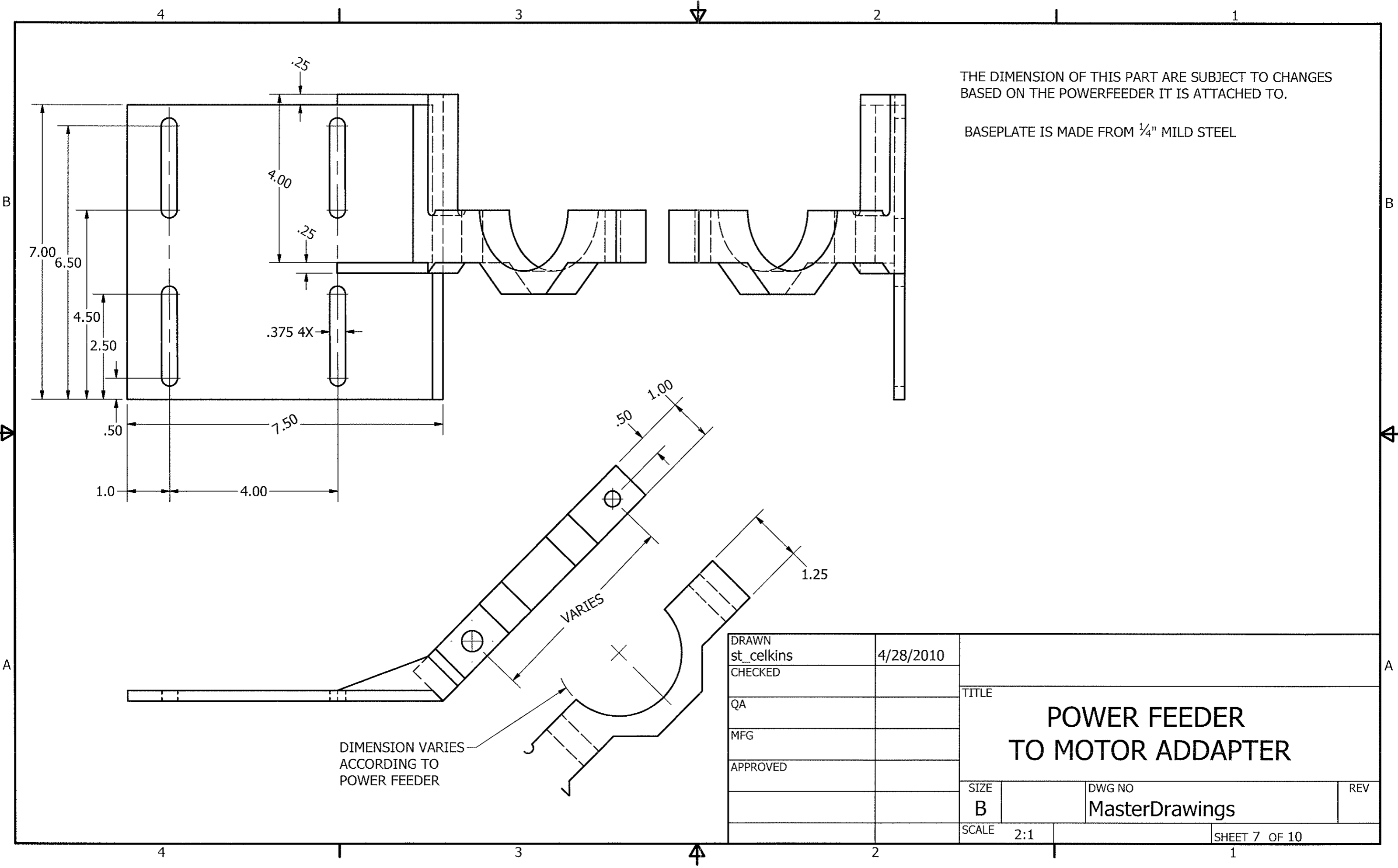

THE DIMENSION OF THIS PART ARE SUBJECT TO CHANGES
BASED ON THE POWERFEEDER IT IS ATTACHED TO.

BASEPLATE IS MADE FROM 1/4" MILD STEEL

DIMENSION VARIES
ACCORDING TO
POWER FEEDER

DRAWN	st_celkins	4/28/2010	TITLE	
CHECKED				
QA			<p style="text-align: center;">POWER FEEDER TO MOTOR ADDAPTER</p>	
MFG				
APPROVED			SIZE	DWG NO
			B	MasterDrawings
			SCALE	REV
			2:1	
			SHEET 7 OF 10	

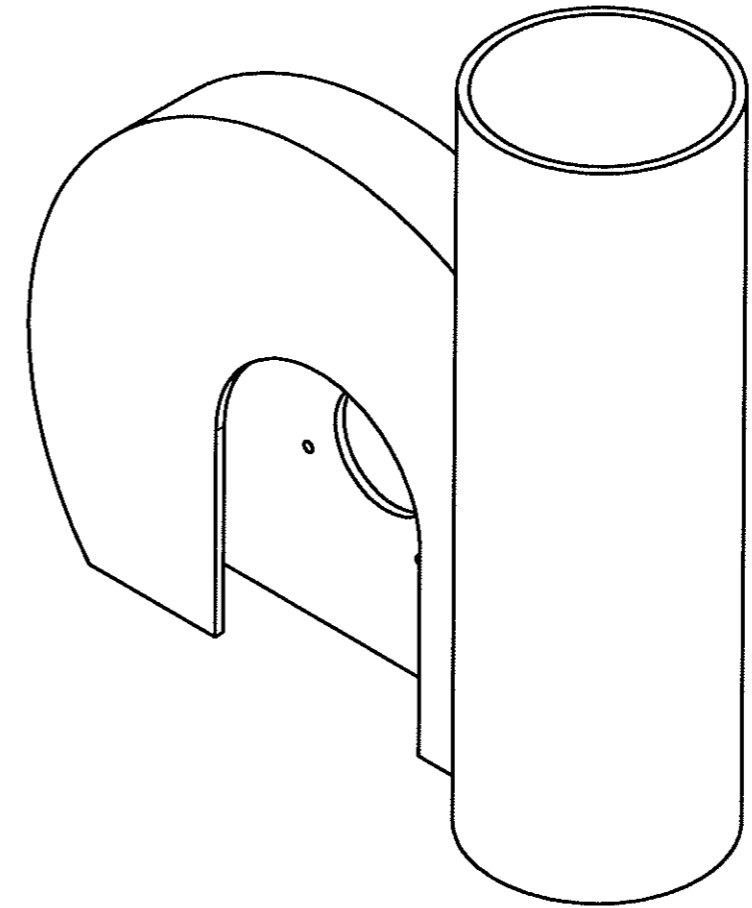
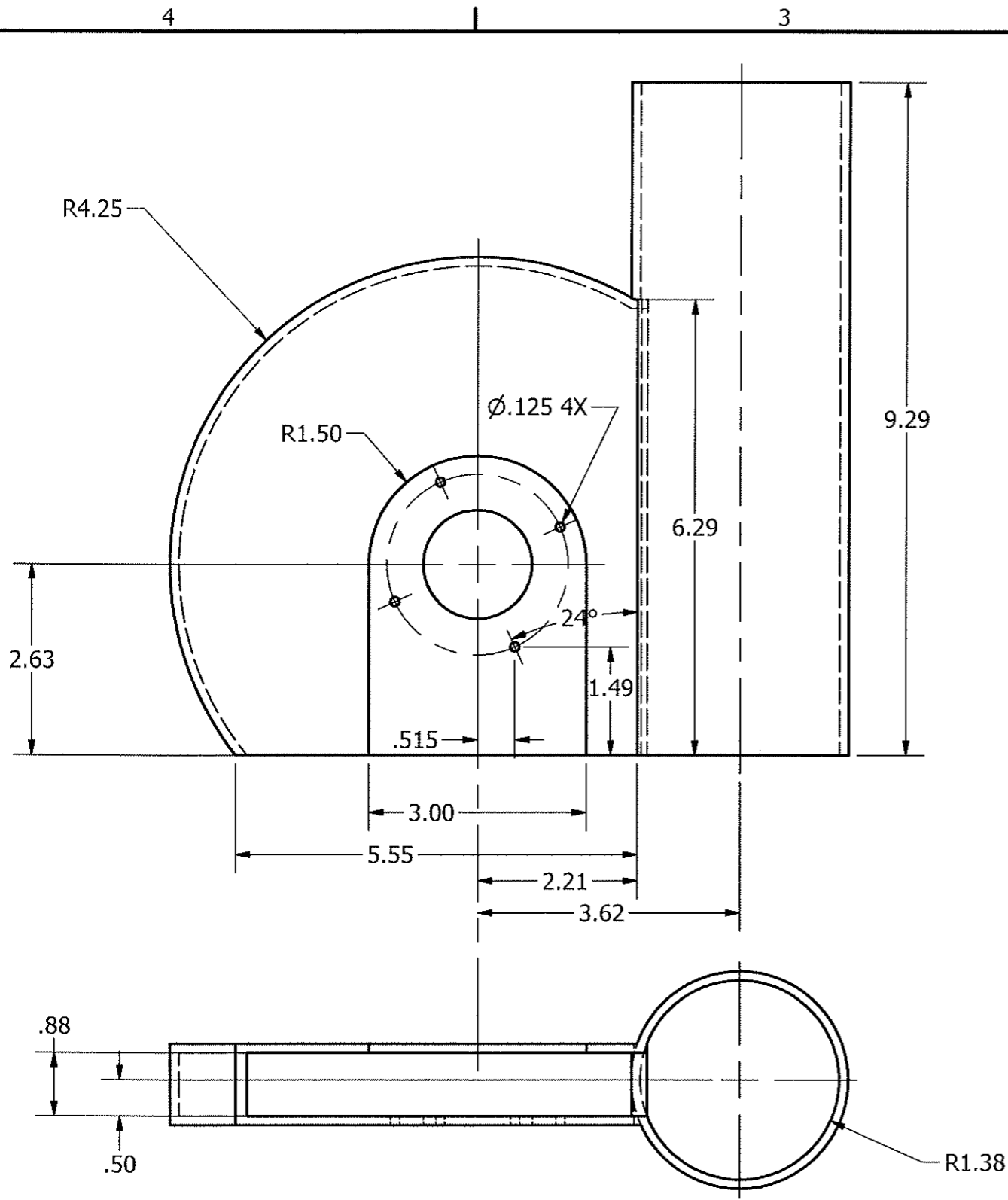

DRAWN	st_celkins	4/28/2010	TITLE DUST COLLECTOR		
CHECKED					
QA					
MFG					
APPROVED			SIZE B	DWG NO MasterDrawings	REV
			SCALE 1:2	SHEET 8 OF 10	

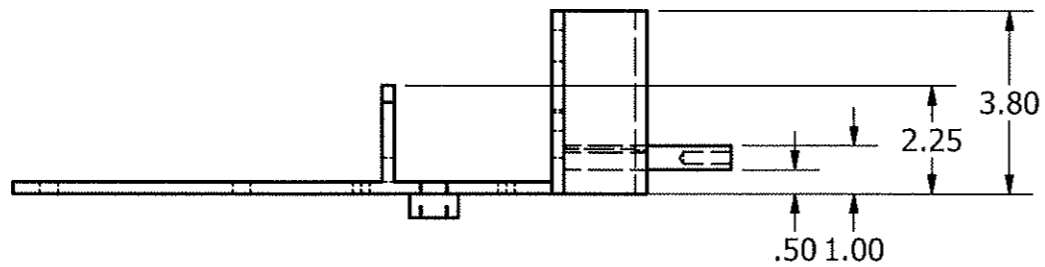
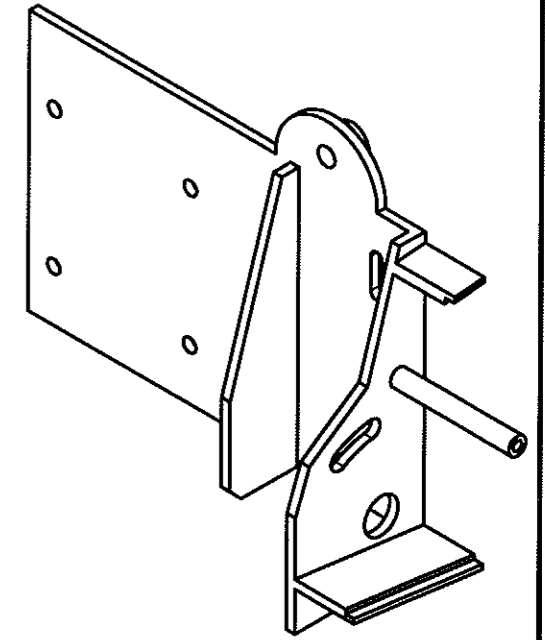
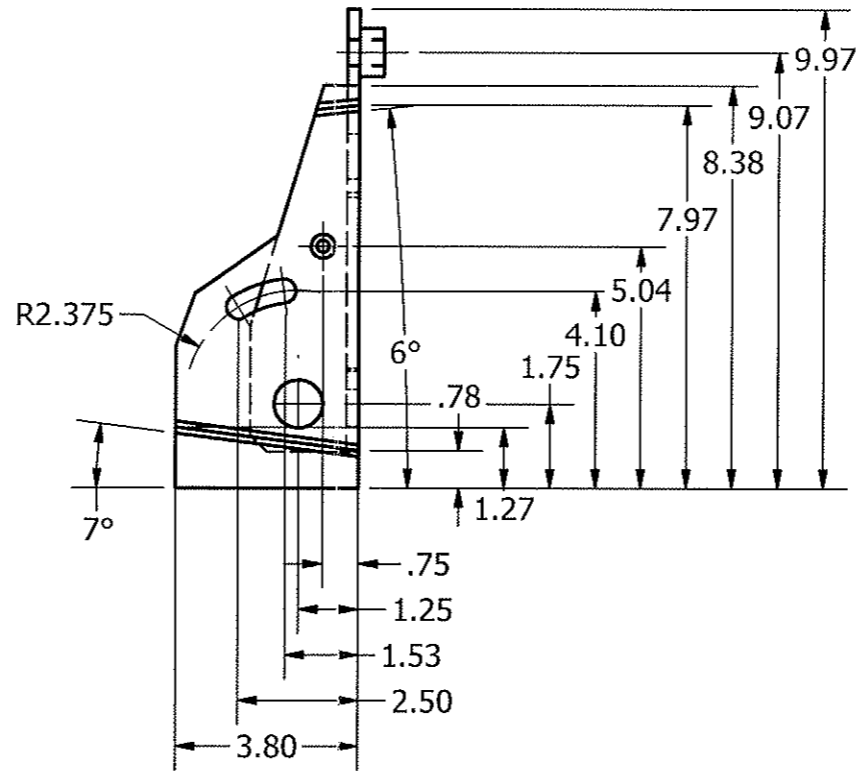
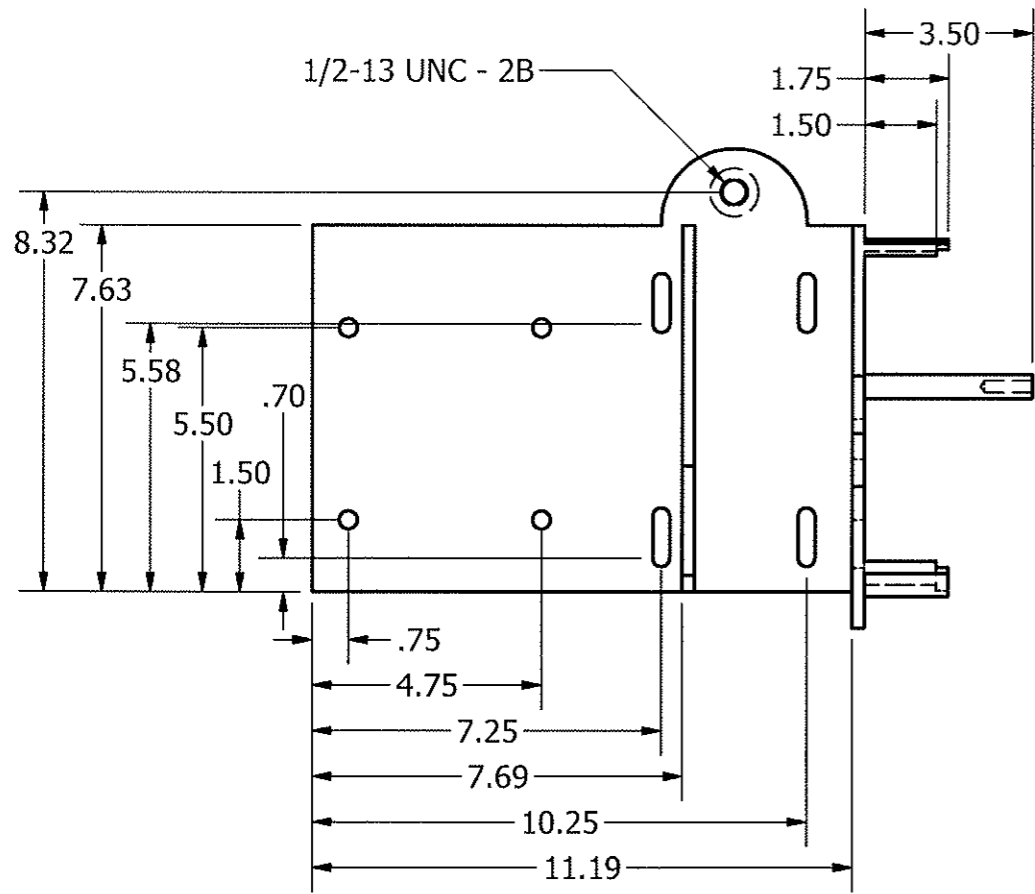

DRAWN	st_celkins	4/28/2010	TITLE				
CHECKED							
QA							
MFG							
APPROVED			<p style="text-align: center;">MOTOR BASE</p>				
					SIZE	DWG NO	REV
					B	MasterDrawings	
			SCALE	1:4	SHEET 9 OF 10		

4

3

2

1

B

B

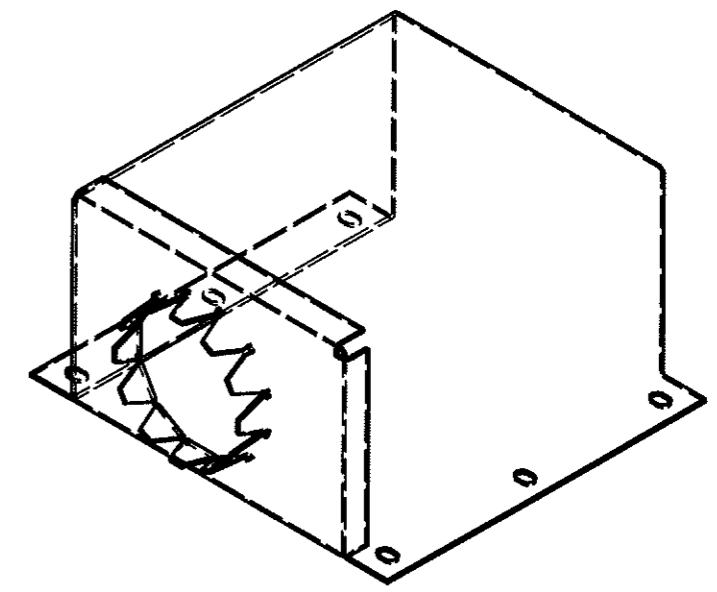
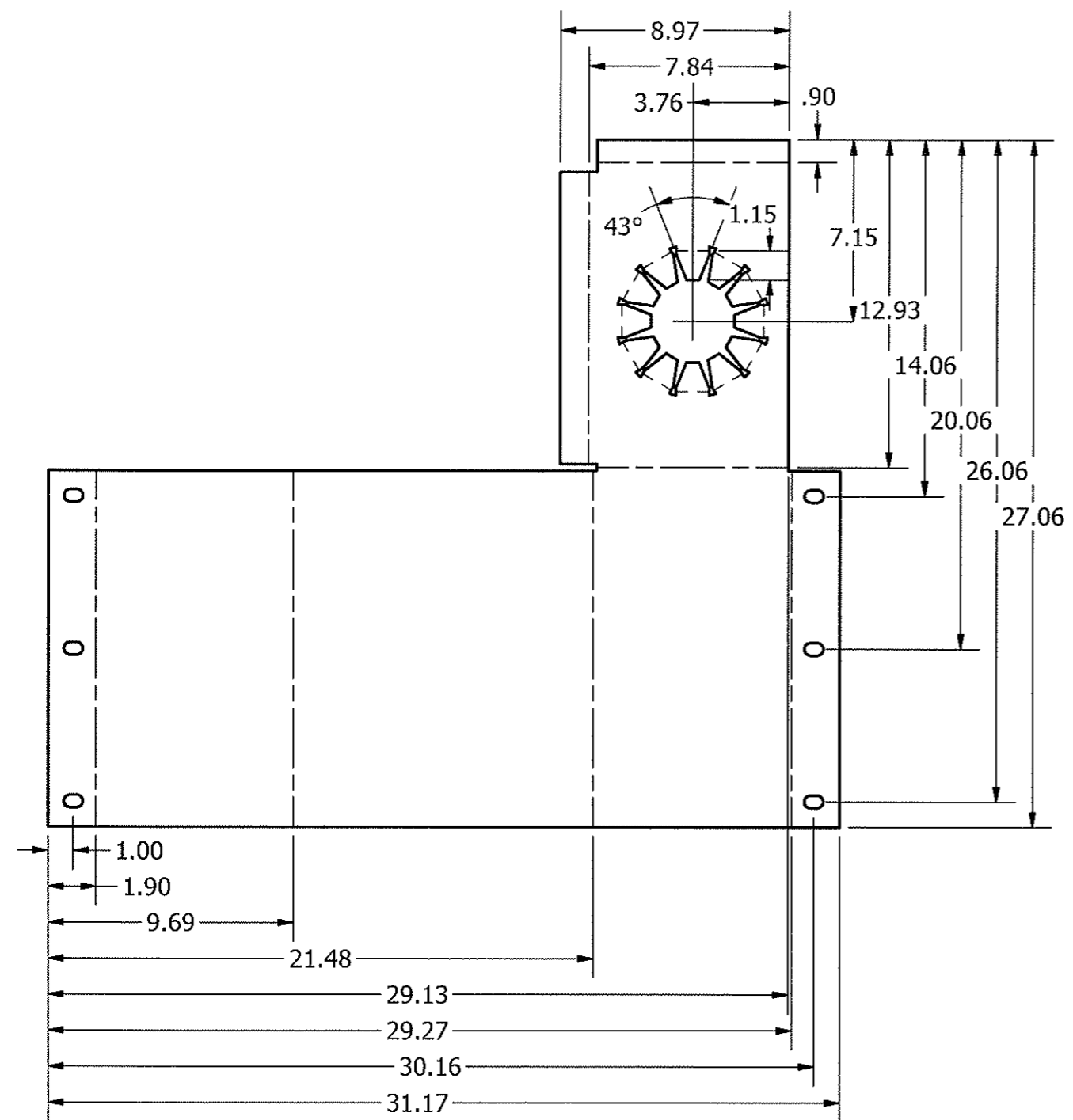

DRAWN st_celkins	4/28/2010	TITLE DUST COVER		
CHECKED				
QA		SIZE B	DWG NO MasterDrawings	REV
MFG		SCALE 6:1	SHEET 10 OF 10	
APPROVED				

4

3

2

1

A

A