

Tarleton State Senior Design Team

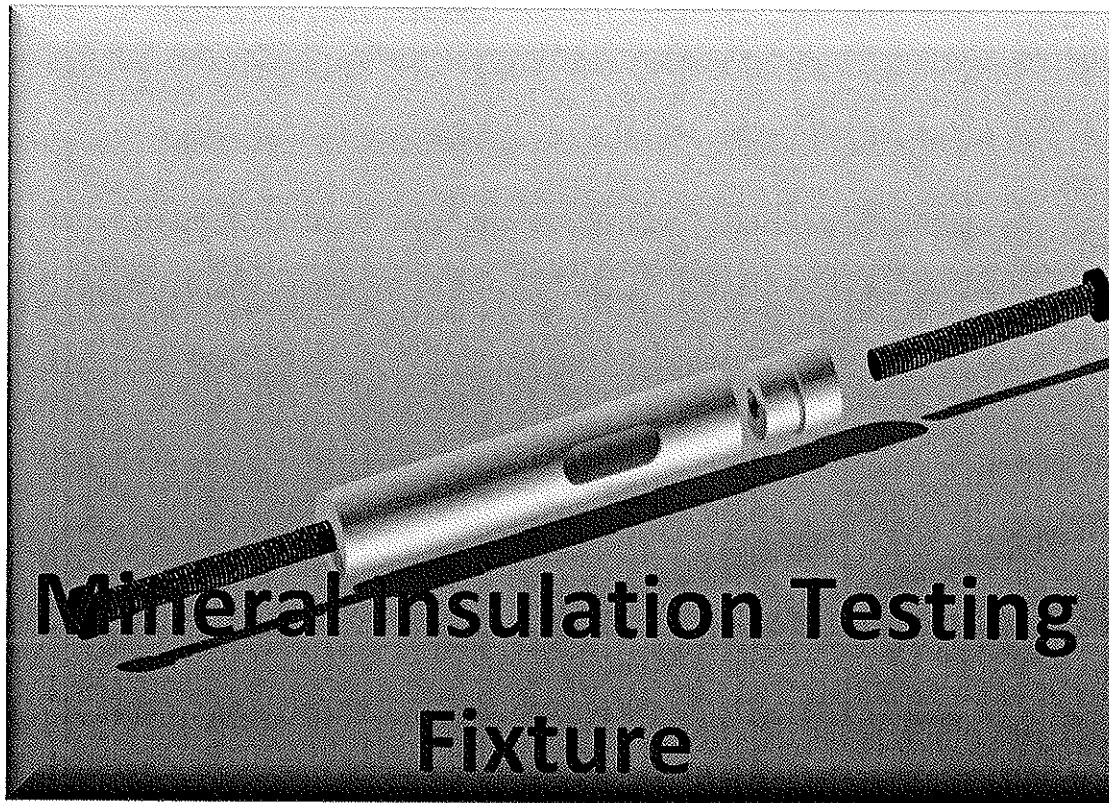

Appleton Electric Inc.

Team Leader: Brian Anderson

Team Member: Cody Miller

**Spring
2010**

Testing Fixture for Resistance Qualities of Insulating Minerals

Project Lead: Brian Anderson

Member: Cody Miller

Submitted for partial fulfillment of requirements for IT 495 senior projects class

Engineering Technology department

April 22, 2010

Project Acceptance Page

Testing Fixture for Resistance Qualities of Insulating Minerals

Team Leader: Brian Anderson

Team Member: Cody Miller

The following affirm that the project deliverables meets the needs of our customer and was accomplished by the project team:

Industrial Sponsor:

Name and Title

Date 5-7-10

Faculty Mentor:

Name and Title

Date 5-7-10

Department Approval:

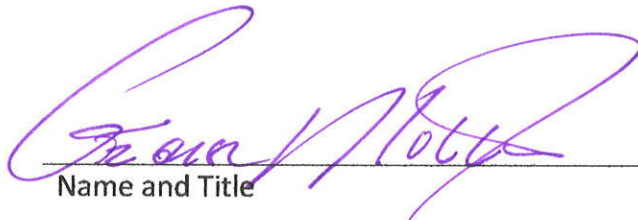
Name and Title

Date 5-7-10

Project Leader:

Name and Title

Date

Table of Contents

Cover Page.....1

Magnesium Oxide Test Fixture2

Project Acceptance Page3

Signature Page.....4

Table of Contents.....5

Executive Summary.....6

 Business Case4

 Project Scope.....7

 Current Process8

 Current State9

Project Strategy.....12

 Recommendations.....13

 Deliverables.....14

 Return On Investment14

Executive Summary

Business Case

Appleton Electric strives to produce the highest quality mineral insulated cable (shown in the figure below) to fit the needs of individual heating applications and surpass customer expectations of a quality product. The “dual” type cable shown below is named for the dual metallic conductors used as heating elements.

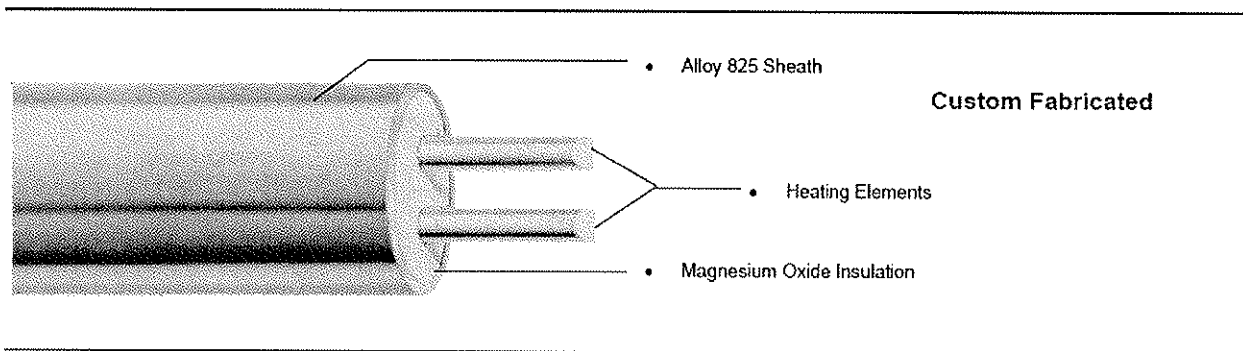

Picture Source:

http://www.forberg.com/customer/forsci/customerpages/pdf/Home_Products_temperature_heattrace_mineral%20insulated.pdf

The description of this project is listed on the EGS website as follows:

“Mineral insulated cable is a metal sheathed cable that uses a metallic conductor as the heating element. The conductor is electrically insulated from the metal sheath with magnesium oxide (MgO). Mineral insulated cable is a series resistance heater that generates heat by passing current through the electrical conductor. Power output per unit length of the cable therefore varies with the applied voltage and the resistance of the conductor.

Mineral Insulated Cables are available with either one or two conductors. The one conductor cable is available in the E Form where a cold splice is provided at both cable ends for electrical connection. The two-conductor cable is available in two forms. The A Form provides an out-and-back circuit with a single cold splice connection at one end. The E Form provides cold splices at both ends of the cable.”

During operation, heat is generated by the series conductor when voltage is applied to the cable. This heat is a result of current passing through the conductor. As applied output and circuit resistance vary during operation, the power output per unit length will also change. In turn, the circuit resistance varies with cable

length. Once an order has been placed, which includes the desired length to meet the customer's needs, a specific conductor is selected for operation based on voltage and desired cable length. This conductor will also provide the customer's desired power output. There are two cable diameters offered by Appleton Electric, one with 30/1000 in. spacing between heating elements/outer sheath and the other with 40/1000 in. spacing. Appleton's unique manufacturing process provides for a thin wall construction. This improves flexibility and ease of installation. This process also allows the use of high performance alloy conductors for high temperature applications.

A high potential test and resistance test are conducted on every section of cable prior to being shipped to the customer in order to verify its ability to meet all electrical requirements once installed in the field. This quality assurance test is an essential procedure that protects the company from liabilities associated with damaged products during the shipping phase.

Additional quality tests, similar to the ones conducted by Appleton, are also recommended to the customer prior to and during the field installation phase in order to identify causes of any potential failures that can result in ground leakage or shortages within the cable. The steps involved in these tests are broken down into checklists which are usually shipped with the product. The checklists can also be downloaded from the company's website:

<http://www.nelsonheaters.com/Download/Check_List_Forms/Checklists_and_Forms.htm>

Project Scope

Our senior design team has been contracted by Appleton to develop a test fixture which can evaluate the purity and consistency of the insulating mineral used in their production of MI Cables. Our industrial partner has developed a rough idea of the fixture which he feels would best accomplish this task. Our goal is to improve this initial design and produce a test fixture that will serve as an additional deliverable to the

company. In completing this goal, our main objective is to conduct the project with the innovation and quality expected from Tarleton State MET/IT graduates. Once completed the new piece should make the tests more consistent, precise, and uniform by making the two conductor rods adjustable and by increasing the surface area of their face. We will also explore additional benefits of using our test fixture and compare the final test results to our teams initial expectations. Through this design/build project, our team will not only gain the experience of a hands on problem solving process, but will also improve our knowledge in the electrical engineering and design fields associated with our degree. Another important goal included in this project is to practice any computer design modeling techniques that need to be refreshed before entering the manufacturing environment as a full time employee.

Current Process

As MI cable rolls off the assembly machine, it is sectioned to desired lengths to fulfill the order from the customer. These sections are inspected in a series of quality tests that are manually conducted by an employee. With each test, the employee must complete a check list that contains important details of the test along with any benchmarks the cable must meet before its shipment date. These tests include two stages of resistance testing and a high potential (hipot) testing. The first stage takes place directly after the assembly process and verifies the internal structure of the cable, such as proper spacing between conducting components. The next set of tests are conducted after the cable has been submerged under water in a pressurized tank. This simulates the field environment and detects any flaws in the outer sheath. If the cable fails in this final stage, it will most likely be caused by damage to the outer sheath that has allowed moisture to enter the cable. This moisture will be absorbed by the MgO, which attracts water molecules, and will become Magnesium Hydroxide. The H₂O must be expelled from the Mg(OH)₂ by cable by cutting the cable near the damaged portion of the sheath, then reversing the reaction with sufficient heat to separate the two.

if the cable fails below a testing requirement, regardless of the stage, it must be sent through an inspection phase where an employee detects the void using a series of elimination. Although the need for inspection is a rare occurrence, Appleton loses valuable man hours and material costs each time a section of cable must be evaluated. The process of introducing the cable to moisture aids in determining whether the failure was caused by outer damage or an internal flaw. But, if the cable fails the initial testing phase, it can become very difficult to pinpoint the reason for its defectiveness.

The main purpose of this project is to design a test fixture that can detect impurities and variance in the mineral insulator magnesium oxide before it has entered the assembly process. This fixture will also be used to further improve the resistance qualities offered in Appleton's product.

Current State

EGS electrical group is a global manufacturer of industrial electrical products for explosion proof, hazardous and ordinary location environments with some of the most well known brands in the industry. EGS is organized into three focused businesses that provide distributors and end-users knowledge and services. Appleton Electric, whose roots go back to 1903, is one of the members of the EGS electrical group and is one of the world's leading brands of products for electrical installations. For over a century, they have designed a wide range of electrical products for both hazardous and non-hazardous locations.

(<http://www.appletonelec.com/aboutus.htm>) Their branch located in Stephenville, TX employs an innovated engineering team that is constantly working on improving the efficiency and design quality of their manufacturing process. By working closely with lead technicians to identify key areas for improvement, their engineers can quickly take these issues to the drawing board in an effort to design a solution for the problem. A good example of this initiative can be seen in Appleton engineer, Jeff Dahl's, solution to detect blockage in the feeding tube that runs from the hopper to the assembly machine. In order to monitor this hopper, which would occasionally become clogged while feeding insulating material into their cable assembly machine, an IR

device was used in conjunction with a written C# program that detects the flow velocity through the feeding tube. It is in this same cable manufacturing process that the need for an additional testing method for the insulating mineral magnesium oxide has been identified. This testing method will act as both a preemptive response to the potential production of large quantities of ineffective cable, and also a new approach for building a product which contains the highest insulation properties possible given the available mineral components.

As previously described, each section of MI cable produced by Appleton is analyzed by a series of testing procedures to assure that it meets the required specifications. This is an essential step in manufacturing process that logs the condition of the finished cable and protects the company from any claims under the product's warranty period that result from damages occurring during the delivery process.

Currently, if a section of cable fails the hipot test prior to being submerged in the pressurized water tank, the point of contamination is usually very difficult or even impossible to identify if it is an impurity issue. In addition, if a defect in the assembly machine is responsible for the failure, it will continue to produce substandard cable until the problem has been fixed. Up until this point in the manufacturing process, the time period for potential contamination not only consists of the cable's assembly stage, but also encompasses the life cycle of the MgO prior to being placed in the hopper. By eliminating the risk of using MgO that has been contaminated in its earliest stage (from the time it is received until it is placed in assembly), the usefulness of the initial hipot and resistance test can be greatly increased by eliminating the need for storage inspection.

One of Appleton's engineers, Jeff Dahl, has developed a rough design for a test fixture which can add this capability to the testing phase of the MI cable. His design utilizes the failure properties associated with impure MgO to simulate a hipot test on the finished product without the need for high compaction (and cost.) The benefit of this addition to the early testing phase is in its ability to flag a defective batch of the insulating mineral before being implemented in the production process. It should be pointed out that due to the

hygroscopic nature of magnesium oxide, Appleton already implements special storage methods to protect the material from moisture. The careful handling and storage method of the MgO practiced by Appleton has been a successful preventative measure of contamination in itself, and there are no records of an entire batch of MgO being damaged while in storage. This being said, the main objective of this project is essentially a preemptive measure which can easily be added to the testing process to potentially prevent a substantial loss in resources. The time required for this test and the cost associated with building the fixture are so small that the ROI, after flagging just one batch of defective MgO, would be enormous.

The new testing fixture's main purpose will be to verify the purification and consistency properties of the MgO used in production. Although magnesium oxide is very vulnerable to moisture, this will not be one of the main concerns in this early testing stage. In the rare instance that the MgO *has* been introduced to moisture while in storage, producing magnesium hydroxide (commonly known as "milk of magnesia" which is commonly used as a laxative or antacid), the process will eventually be reversed by the assembly machine's heating element while in the hopper. Examples of impurities that are not expelled during heating process include low levels of boron, sulphur, and iron left over from the calcination process, and any other ferrous materials that are common in Appleton's assembly environment, such as stainless steel shavings. Detecting excessive amounts of these impurities can be a major asset to the production of Appleton's MI cable.

Further benefits of this design proposal have also been recognized by our team's industrial partner, Mr. Dahl, that can further increase the quality of the Mineral Insulated cable produced by Appleton to a level even greater than the product's current rating. This can be accomplished by 1) adding different proportions of the mineral's granular size to our test fixture's chamber, 2) assigning constants for the experiment; these will be the distance between conducting rods, the current provided by the hipot tester or megger, and the insulation properties of the MgO samples (although the resistance will be negatively influenced with repetitive electrical flashes due to a carbon rich track that forms between the two rods), and 3) recording the results to identify

patterns of increasing resistance. Using this method, Appleton can eventually attain optimized properties associated with individual batches of MgO. Furthermore, they can even create their own “optimized mixture” that produces the highest resistance qualities possible by mixing a broad spectrum of particles. This mixture can be stored for an extended period of time, allowing gravity to desegregate the created batch, and once again tested with our fixture by scooping a small sample for verification, and dumping the rest directly into the hopper to limit the creation of new void locations.

When compared to other methods of testing quality, such as tap density readings, our team’s test fixture can provide a new technique that is less invasive to compaction (which minimizes segregation), less vulnerable to error, and a much quicker process. By observing the arc points shown on the hipot machine, knowledge of particle distribution and flow properties are no longer essential; consequently, the test operator can be an employee from any level of the company.

Project Strategy

Appleton has requested that our senior design team work in parallel with their engineers to produce a design for a test fixture which can prevent the use of a substandard insulating mineral for production; their hope is that our extensive background in component design and material properties can improve their initial ideas outlined by a rough model of the test fixture. As defined by Appleton, our main deliverable will be a design of the test fixture that best meets the needs of the company. We will also provide a manufactured representation of the test fixture for trial in its actual production environment. Once the initial fixture has been tested, any improvements that can be made will be included in our final build of the fixture, which will be utilized as needed in Appleton’s every day production process.

In order to produce the ideal deliverables for this design/build project, several MET/IT tools such as computer design software and machining equipment found in our engineering technology department’s machine shop

will be used. Our feedback for each print out during the design phase and our initial build of the fixture will come from one of the company's engineers, Jeff Dahl, who will influence our modifications to the subsequent designs. Our analysis of the final build of the fixture will be a combination of both Mr. Dahl's satisfaction in the design and the testing results acquired from the testing machines in Appleton's manufacturing facility. These results will also serve as a deliverable to the company by verifying the expected change to testing results when the fixture's conducting rods are adjusted.

In order to effectively optimize the testing procedure associated with our fixture, the team will utilize Autodesk software, such as Inventor and Autocad, to produce the drawings for inspection. To complete the build phase of our project, we will use machining tools made available by our MET/IT department, including a lathe, milling machine, and other instruments required for completion. Based on the input from Mr. Dahl, the design for our fixture will constantly be updated until we feel that the needs of our company have best been met using our available resources.

Recommendations

Our recommendations for the final test fixture include several modifications to the original design. The first fixture, which was given to us by Mr. Dahl, contained conducting rods, used to simulate the heating elements in the MI cable, that were made with pointed tips. In order to achieve a more consistent arc point, the rods in our final design are flat at the ends. This gives the arc points a greater surface area and in turn provides a more accurate flow of current at the point of failure. Our design also allows for interchangeable leads which can easily be switched out to simulate the desired cable for testing. This requires the machining of fixtures with different sizes of tapped holes. It will also have adjustments available by the use of screw threads to change the distance between the two conductor rods.

Deliverables

Appleton will receive the following:

- Drawings of the approved design of fixture

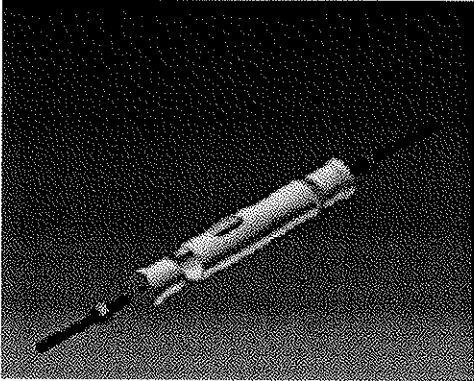

- Completed test fixture manufactured by our team

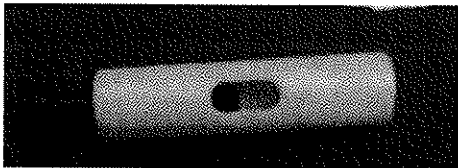

- Test results for the final design

Return On Investment

Currently, there are no actual numbers that can be calculated for an accurate ROI number. Appleton has not yet received a batch of MgO that has caused a massive failure in the final product. If the test fixture were to detect a potentially harmful batch of Magnesium Oxide, the return on investment for our test fixture would be enormous.

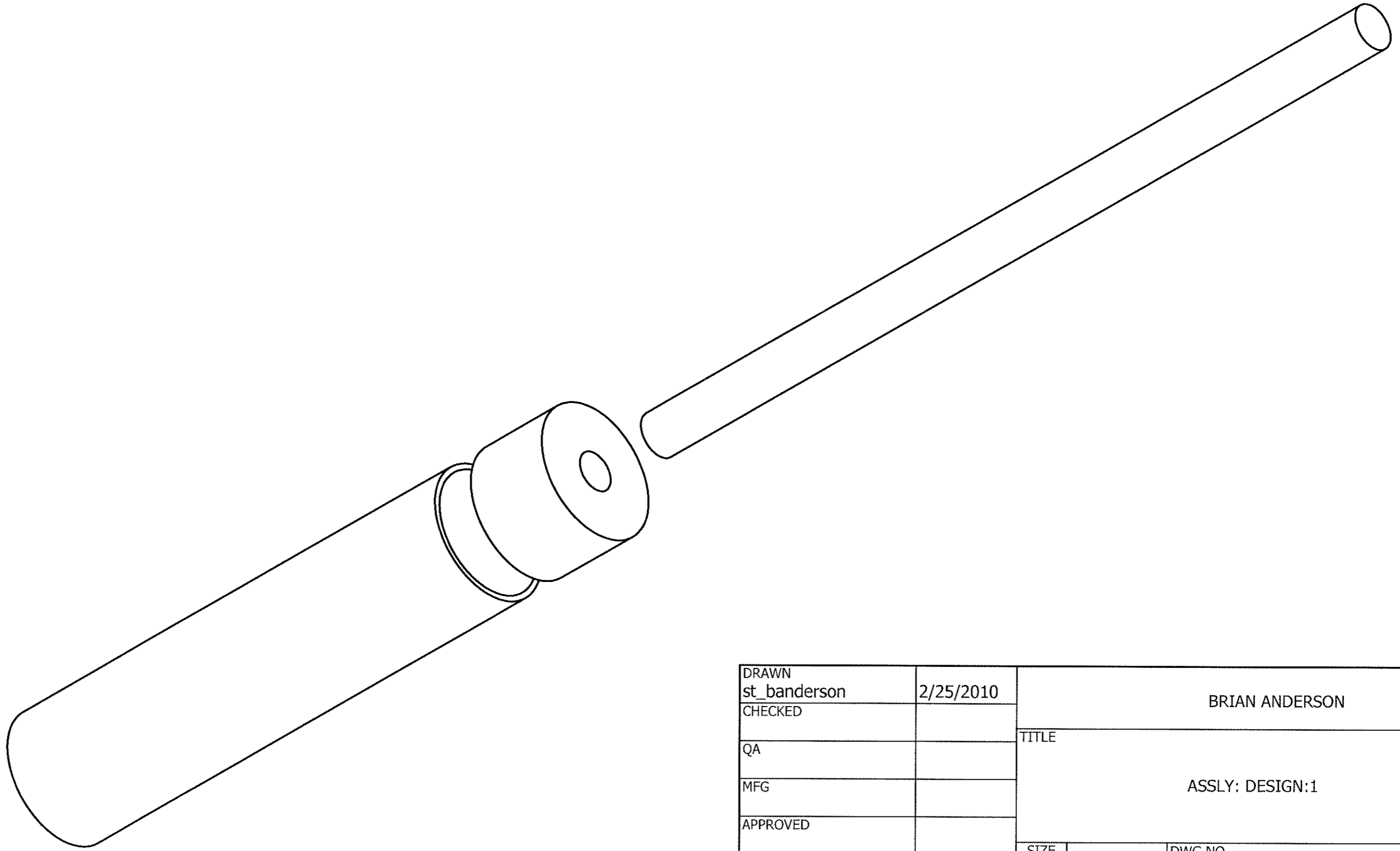

DRAWN	st_banderson	2/25/2010	BRIAN ANDERSON		
CHECKED			TITLE		
QA			ASSLY: DESIGN:1		
MFG					
APPROVED					
			SIZE	DWG NO	REV
			B	Assembly1	
			SCALE 2:1	SHEET 1 OF 1	

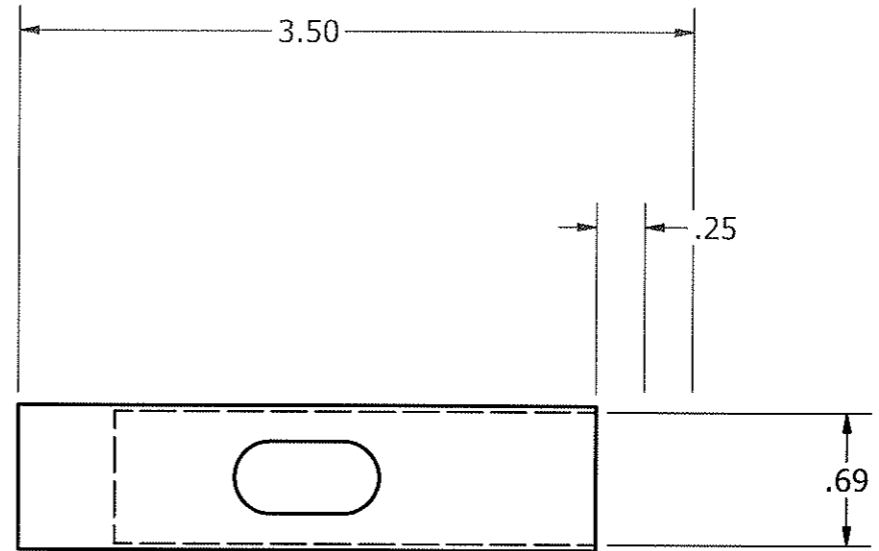
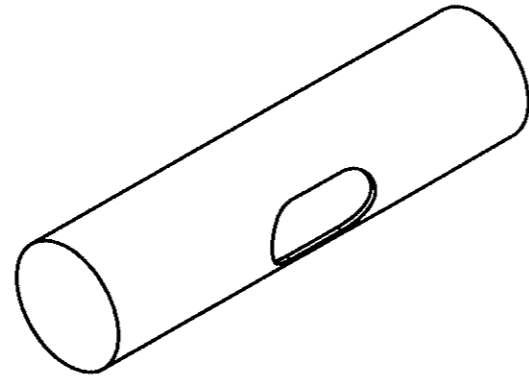
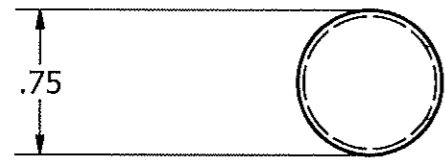

3/4-10 TAP

DRAWN	st_banderson	3/4/2010	BRIAN ANDERSON		
CHECKED			TITLE		
QA			SET PIECE DESIGN:1		
MFG					
APPROVED					
			SIZE	DWG NO	REV
			B	feb23 set piece	
			SCALE 1:1	SHEET 1 OF 1	

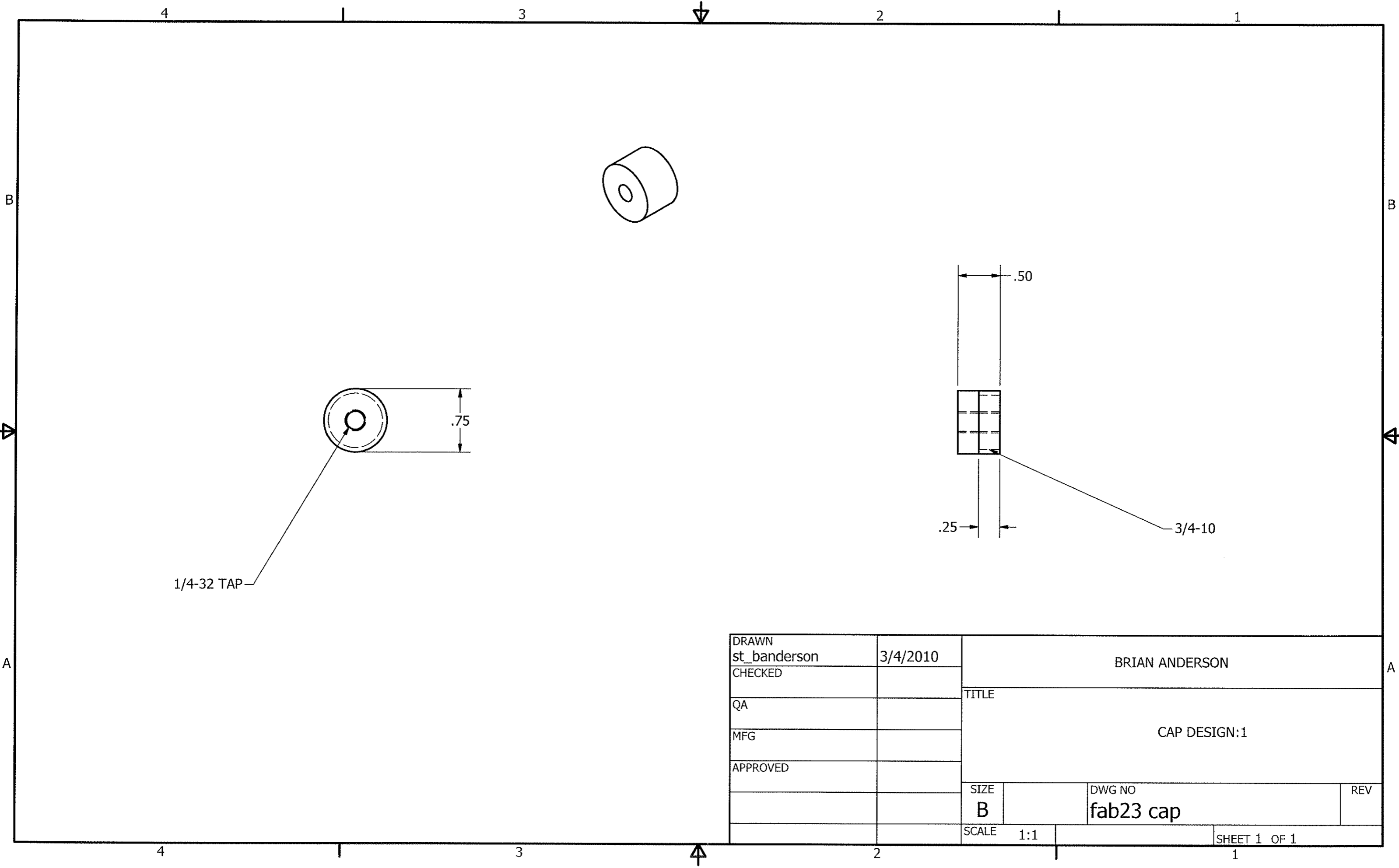

1/4-32 TAP

.75

.50

.25

3/4-10

DRAWN	st_banderson	3/4/2010	BRIAN ANDERSON		
CHECKED			TITLE		
QA			CAP DESIGN:1		
MFG			SIZE		
APPROVED			DWG NO		
			B	fab23 cap	REV
			SCALE	1:1	SHEET 1 OF 1

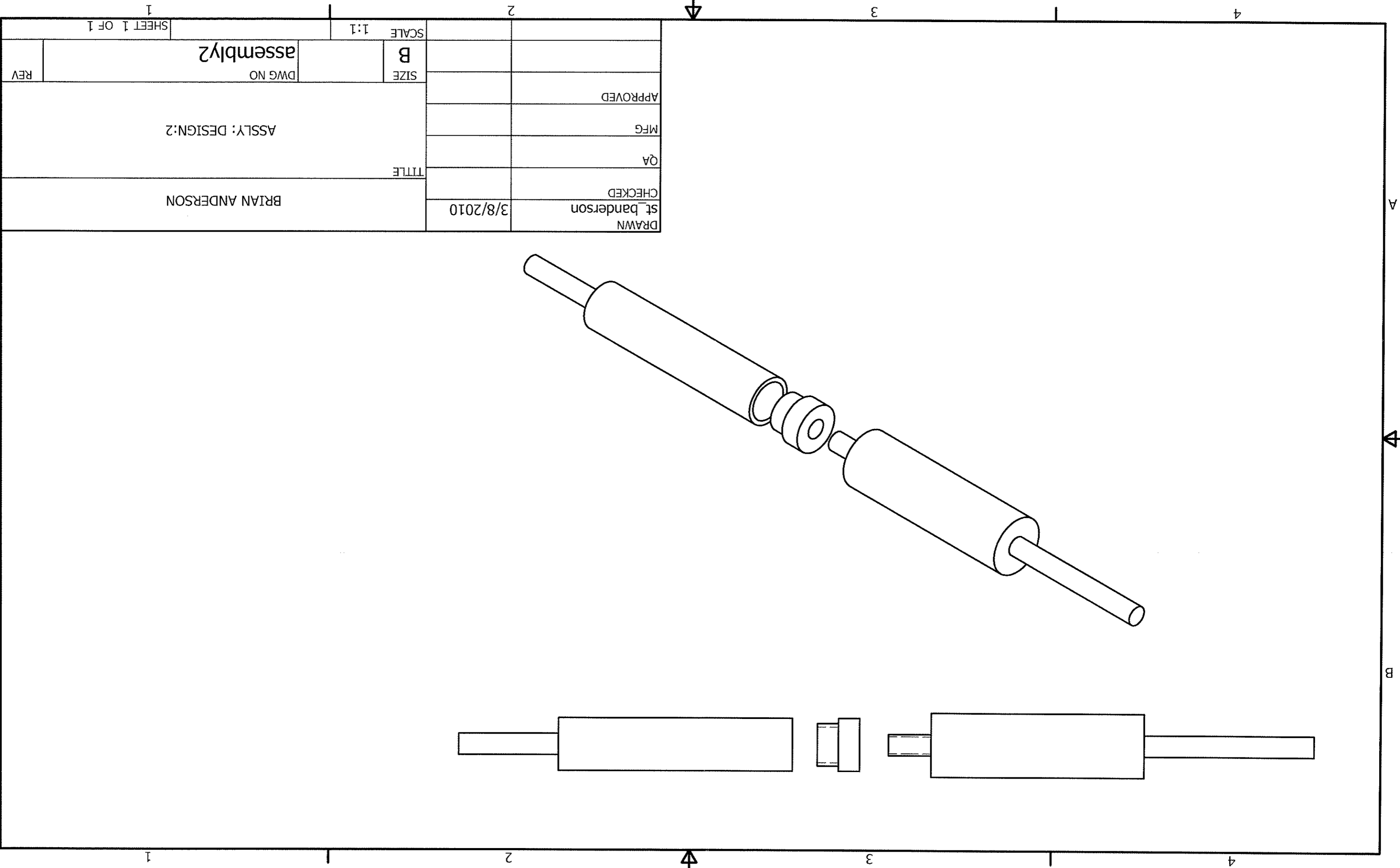

DRAWN st_panderson		3/8/2010		CHECKED			
QA				MFG		APPROVED	
TITLE		ASSEMBLY: DESIGN:2		DWG NO		assembly2	
SIZE		B		SCALE		1:1	
REV				SHEET 1 OF 1		1	

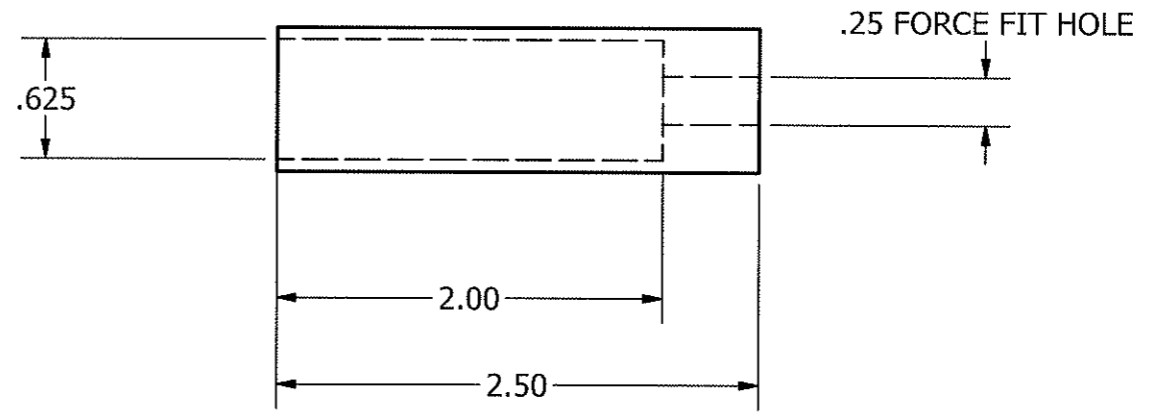
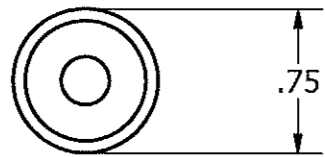

DRAWN	st_banderson	3/8/2010	BRIAN ANDERSON		
CHECKED			TITLE		
QA			CYLINDER SLEEVE DESIGN:2		
MFG			SIZE		
APPROVED			DWG NO		REV
			Mar 8 cylinder sleeve		
			SCALE 1:1	SHEET 1 OF 1	

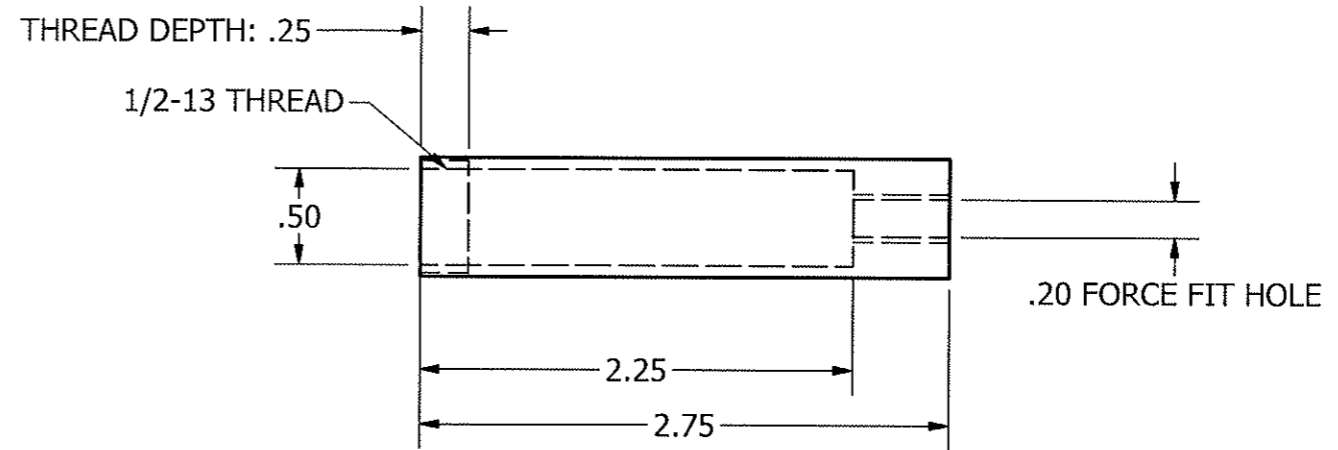
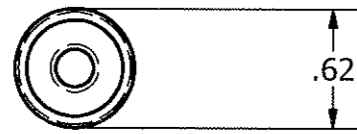

DRAWN	st_banderson	3/8/2010	BRIAN ANDERSON		
CHECKED			TITLE		
QA			SET PIECE DESIGN:2		
MFG					
APPROVED					
			SIZE	DWG NO	REV
			B	Mar 8 set piece	
			SCALE 1:1	SHEET 1 OF 1	

4

3

2

1

B

B

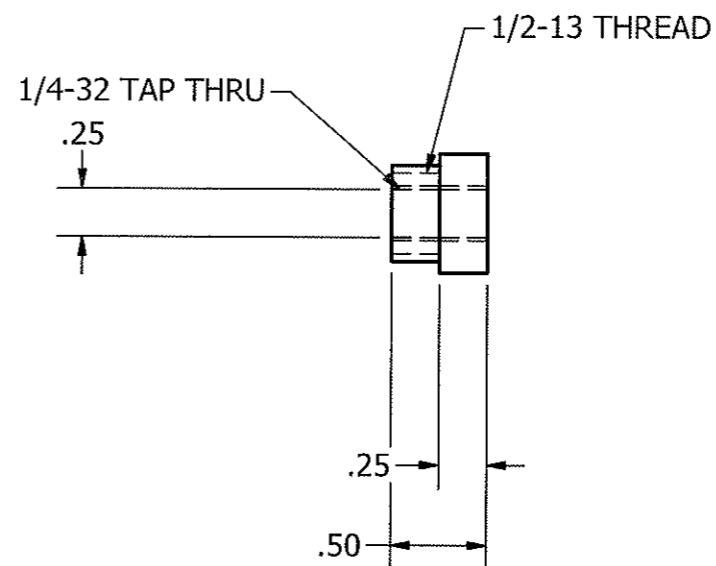
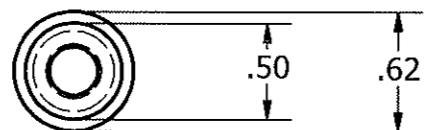

A

A

A

A

4

3

2

1

DRAWN	st_banderson	3/8/2010	BRIAN ANDERSON		
CHECKED			TITLE		
QA			CAP DESIGN:2		
MFG					
APPROVED					
			SIZE	DWG NO	REV
			B	MAR 8 CAP	
			SCALE 1:1	SHEET 1 OF 1	

4

3

2

1

B

B

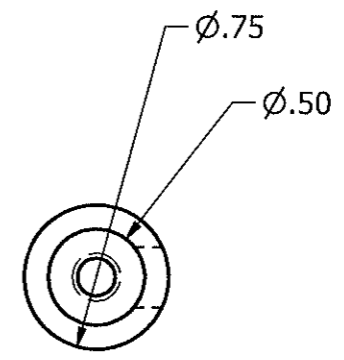
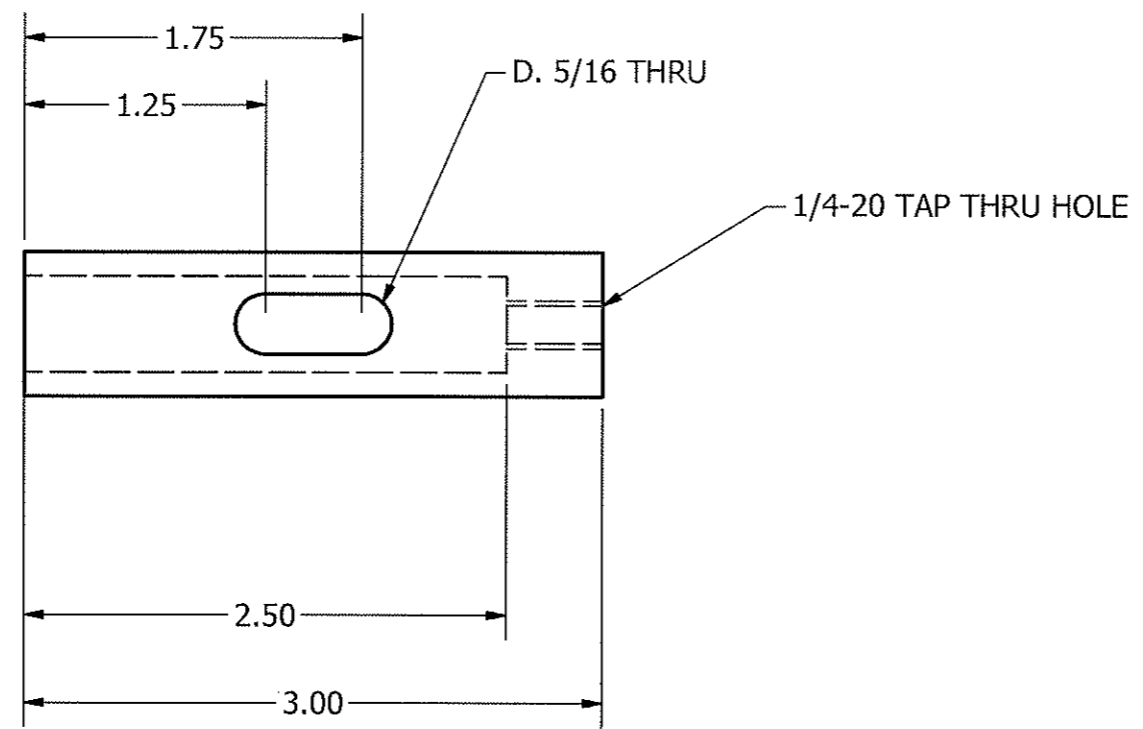

A

A

A

A

DRAWN	st_banderson	4/22/2010	BRIAN ANDERSON		
CHECKED			TITLE		
QA			SET PIECE: FINAL		
MFG					
APPROVED					
			SIZE	DWG NO	REV
			B	final drawing	
			SCALE 1:1	SHEET 1 OF 1	

4

3

2

1



4

3

2

1

B

B

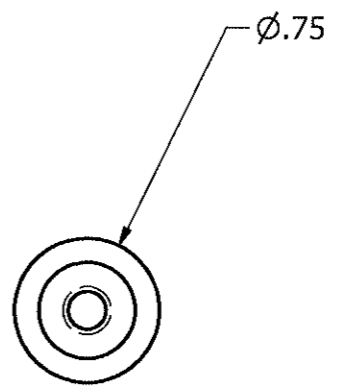
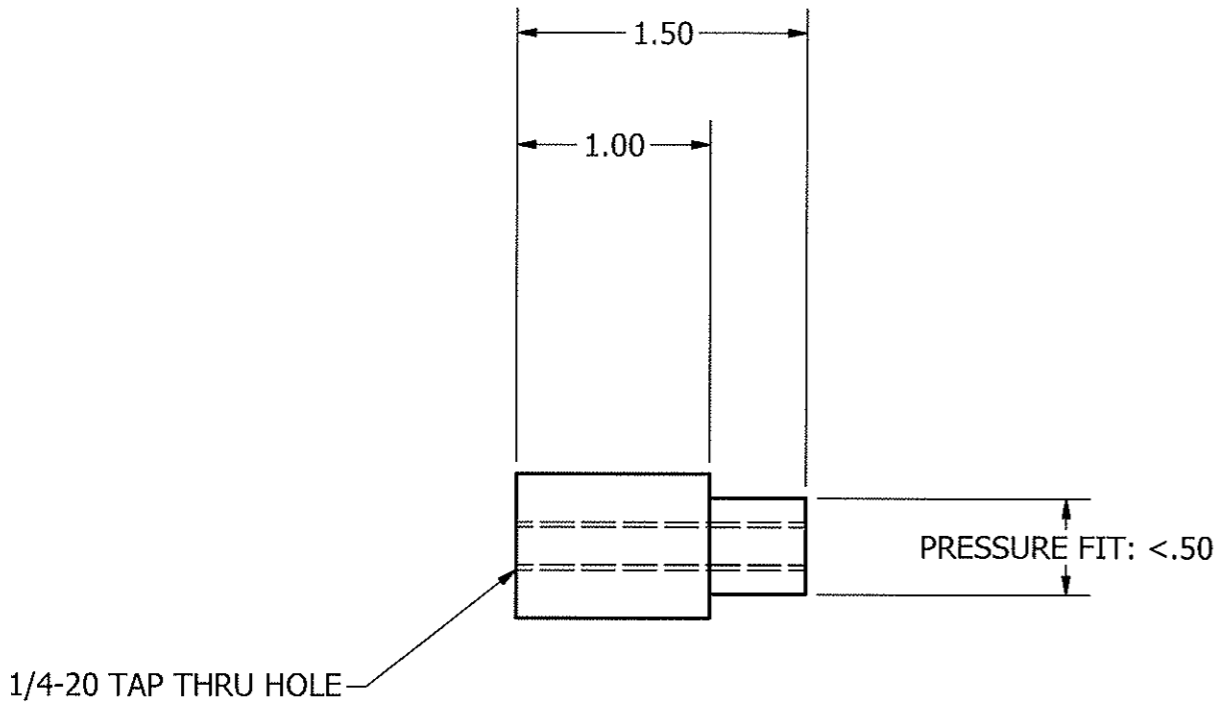

A

A

DRAWN	st_banderson	4/22/2010	BRIAN ANDERSON		
CHECKED			TITLE		
QA			CAP: FINAL		
MFG					
APPROVED					
			SIZE	DWG NO	REV
			B	FINAL CAP	
			SCALE	1:1	SHEET 1 OF 1

4

3

2

1

A

A