

FIBERGRATE PULTRUSION HEATERS COVERS

Project lead: CLIFF DRAY

Members: ZANE MONTGOMERY

Submitted for partial fulfillment of requirements for IT 495 senior projects class

Engineering Technology Department

Tarleton State University

APRIL 30, 2010

Project Acceptance Page

Fibergrate Pultrusion Heater Covers

Team Leader: Clifford Dray

Team Member: Zane Montgomery

The following affirm that the project deliverables meets the needs of our customer and was accomplished by the project team:

Industrial Sponsor:

Name and Title 5-5-10
Date

Faculty Mentor:

Name and Title 5-5-10
Date

Department Approval:

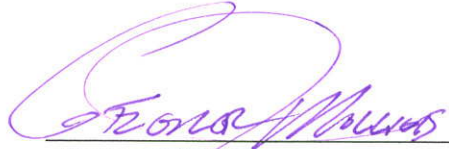
Name and Title 5-5-10
Date

Project Leader:



Name and Title 5-5-10
Date

Table of Contents

Project Title Page.....1

Project Acceptance Page2

Table of Contents3

Executive Summary4

Business Case.....4

Current Process.....4

Project Scope and Goals5

Business Need6

Current State6

Project Scope and Goals7

Project Strategy7

Recommendations8

Deliverables.....8

Project Cost9

Return on Investment9

Executive Summary

Business Case

Fibergrate Composite Structures Inc. has been having issues with the way they clamp their heaters to the pultrusion dies during production. Fibergrate is a world leader in the Fiberglass Reinforced Plastics (FRP) industry. Fibergrate has many different types of dies from there I-shaped dies for there pultruded grating products to their square tube dies for their handrail products. Fibergrate needs a method that must prove to be safe and easily changed out during production. The heaters must stay in contact with the die at all times and improve on heater efficiency.

Current Process

As of now they are strapping three big hose clamps completely around the dies and placing the strip heaters somewhere close to the middle and then tightening the clamps. This method works for right now, but it has some serious problems. The main problem is that it is very difficult to change out during production. The heaters have to be in the right position and the workers have to keep them in that spot while they tighten the clamps down. After running parts through the dies,

everything in contact with the die becomes way too hot to touch without PPE (Personal Protective Equipment), and so the workers have to wear bulky gloves or risk burning their hands while taking off the hose clamps and heaters. Also there is an issue with maintaining heater contact to the dies. The three hose clamps are using three pressure points to maintain contact, but the gap between the hose clamps creates a place where the heater can raise up and not stay in contact with the die. The other problem is that the heaters are out in the open with nothing covering or insulating them. Half of the heat that is being created is going toward the mold, while the other half is making the environment for the workers warmer. While the workers probably would not complain about that on a cold day, but Fibergrate is losing heat that could be redirected toward the die or at least stay closer to the die.

Project Scope and Goals

Senior Design Team consists of Tarleton State Engineering Technology Students and has been contracted by Fibergrate Composite Structures Inc to design a new method for attaching their strip heaters to their pultrusion dies.

The objective of the project is to create a new method, improve heater efficiency, and engineer the method to be safely and easily changed out during production. The deliverables are to provide detailed 2-D drawings and 3-D drawings of the design, along with a bill of materials.

Business Need

Current State

Fibergrate is a world leader in providing FRP products and as a result of this demand they need a faster and safer way of changing out their pultrusion strip heaters. The way they are attaching the strip heaters now is definitely working for them, but there has to be a better way than that. It takes too much time for the workers to have to change out the heaters and take the hose clamps off. The heaters need to be more efficient in transferring heat to the dies, because there is heat that is just radiating towards the atmosphere and could be kept closer to the die.

The scope of this project encompasses only the pultrusion portion of manufacturing, not the assembly and final output of the product. Senior Design Team wishes to develop a design that will cover the heaters and allow the heaters to be easily removed from the dies. Also the design will help to hold more heat closer to the die. The pultrusion production line operates using a pull system so that fiberglass and fiber-mat is pulled through a vat of resin. As it reaches the heater area, the catalysts that are in the resin start to release energy in the form of heat and as a result produce a material that is hard and sturdy. The finished product after it's cooled is very durable and has exceptional strength.

When completed, Tarleton State University Senior Design Team will provide Fibergrate with a series of decision support tools and analyses that will provide the following on Flash Drive:

- 2-D detailed drawings and 3-D CAD drawings of the part.
- Bill of Materials

Project Scope and Goals

Senior Design Team consists of Tarleton State Engineering Technology Students and has been contracted by Fibergrate Composite Structures Inc to analyze and provide a method for attaching their strip heaters to their pultrusion dies.

The objective of the project is to create a new method, improve heater efficiency, and engineer the method to be safely and easily changed out during production. The deliverables are to provide detailed 2-D drawings and 3-D drawings of the design, along with a bill of materials.

Project Strategy

Fibergrate Composite Structures Inc has requested that the Senior Design consulting team work in parallel with their engineers to produce a method that will be safely and easily changed out during production. As defined by Fibergrate, the main deliverable from the Senior Design consulting team will be the design of a method for attaching their strip heaters to their pultrusion dies. In order to produce a design we designed the part in AutoCAD and after several modifications we settled on a final design. Then we began drawing the design as a 3-D model in Inventor. After we finished the 3-D model, we started gathering information for a Bill of Materials.

Recommendations

The proposed solution is to bolt a die metal cover to the die and have a slot for the heater to slide in from the side of the die. Then have four set screws placed in the middle of the cover to tighten down on to the heater. This way there are only four steps in order to change during production if using side cable heaters.

1. Loosen set screws
2. Slide heater out from under the cover
3. Loosen bolts that hold cover in place
4. Slide and detach cover

The other type of heater being used in production is a two cable end heater. The design solution will work with this heater, but in order to change heaters the whole cover must come off. We would recommend using the side cable heater, in order to optimize the changeability of the heaters.

The workers will still have to wear gloves when handling the heaters and covers after production use, but the handling time has been greatly reduced.

This cover design will increase heater efficiency by keeping the heater covered and increase the amount of heat that stays closer to the die.

With this design the heaters will be easily changed out and efficient during production.

Deliverables

Fibergrate Composite Structures Inc will receive the following:

- 2-D detailed drawings and 3-D drawings of the heater covers.
- Bill of Materials List.

Project Cost

The cost of the die steel that will be used is:

- $\frac{3}{4}$ " x 2" HR Flat Bar x 20' \$ 4.35 /ft\$87.00
 - Delivery time would be in 1-2 Days
- 8 – $\frac{1}{4}$ x 20 UNC Hex Head Bolts.....\$10.00/pack of 50
- 8 – $\frac{1}{4}$ x 20 UNC Hex Nuts.....\$8.13/pack of 50
- 16 – $\frac{1}{4}$ x 20 UNC Hex Head Set Screws.....\$9.80/pack of 50
- This does not including the price of machining the key slots in the die or machining the covers.

Return on Investment

The payback for this is difficult to calculate with numbers. The payback for this project would be the time saved by the ease of changing heaters and the safety factor has greatly increased. If a heater goes out during production then it becomes very difficult and unsafe to change the heaters out when hot. With the heater covers this process becomes very easy and safe. With the old process, it would take two workers to setup and now it takes one worker. Also the heater covers will improve the quality of the parts produced, by positioning the heaters in the right position every time. This in turn eliminates defects such as blisters. This design solution definitely improves the main objective of attaching the heaters to the die.

PULTRUSION HEATER COVERS

DESIGNERS:

PROJECT LEAD: CLIFF DRAY

PROJECT MEMBER: ZANE MONTGOMERY

FNAME

REVDATE

USER

REVISIONS				
ZONE	REV	DESCRIPTION	DATE	APPROVED

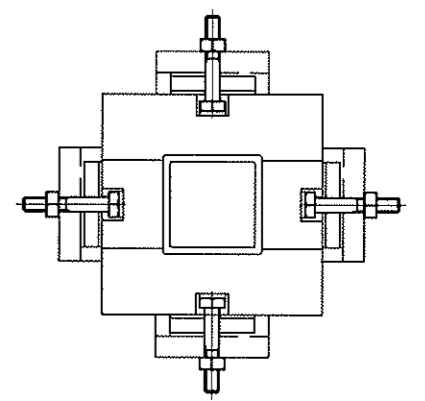
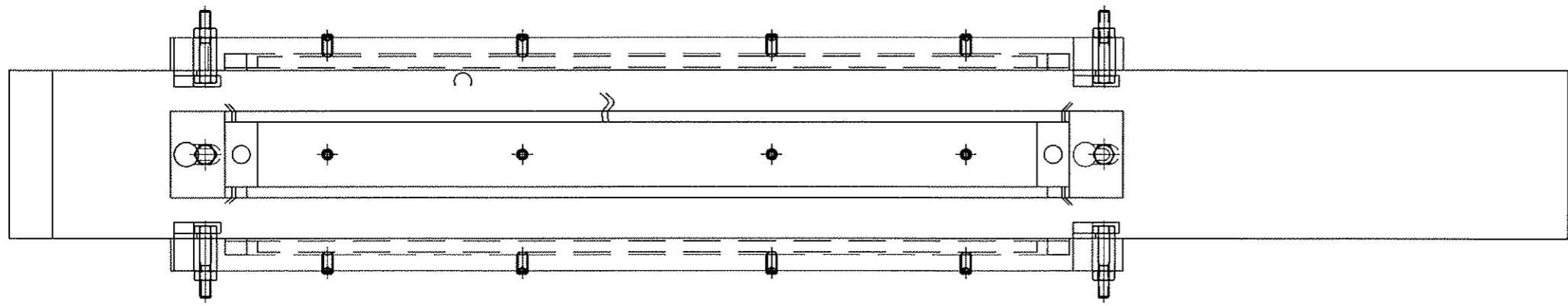
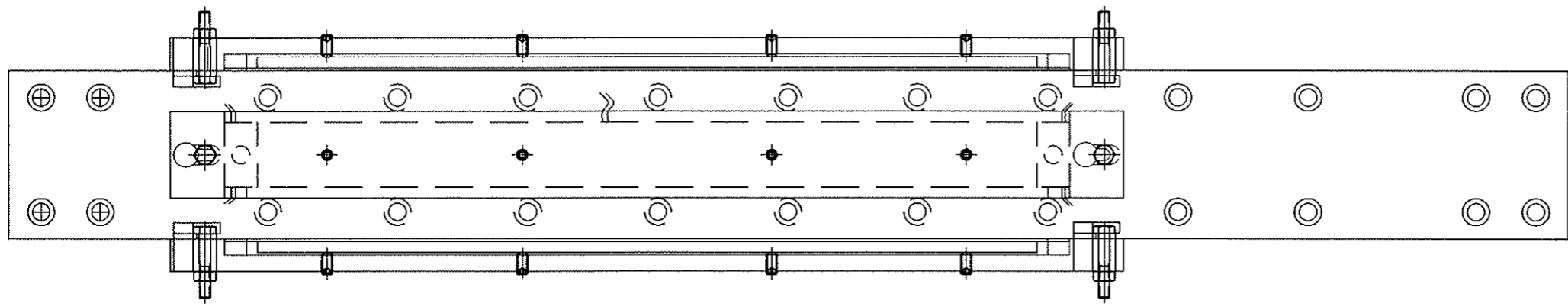

TSU SENIOR PROJECTS			
FIBERGRATE COMPOSITE STRUCTURES INC PULTRUSION HEATER COVERS			
SIZE	FSCM NO.	DWG NO.	REV
SCALE	ICD & ZM		SHEET 1-4

FNAME

REVDATE

USER

REVISIONS				
ZONE	REV	DESCRIPTION	DATE	APPROVED

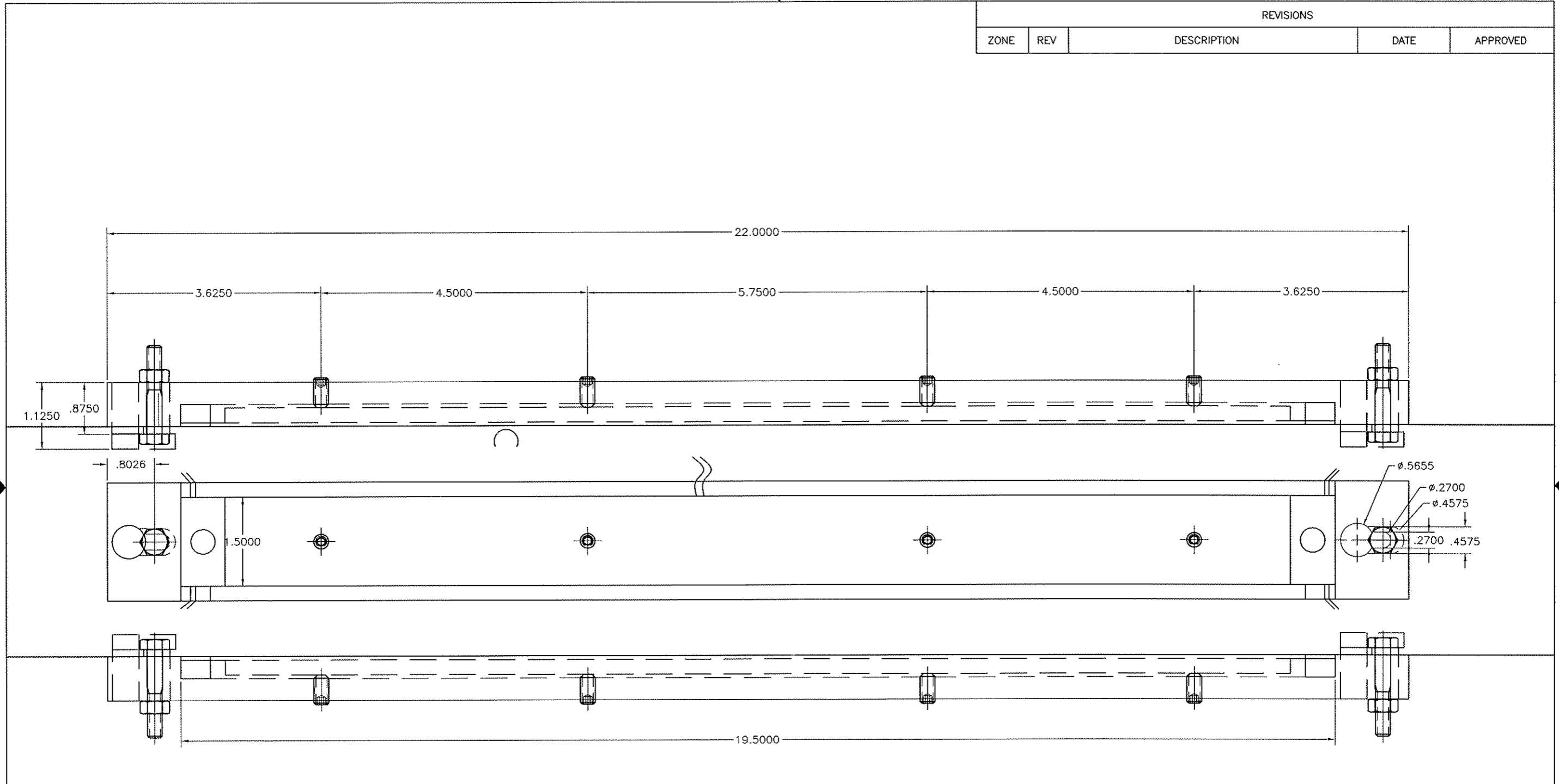

TSU SENIOR PROJECTS			
SIZE	FSCM NO.	DWG NO.	REV
SCALE	ICD & ZM		SHEET 2-4

FNAME

REVDATE

USER

REVISIONS				
ZONE	REV	DESCRIPTION	DATE	APPROVED

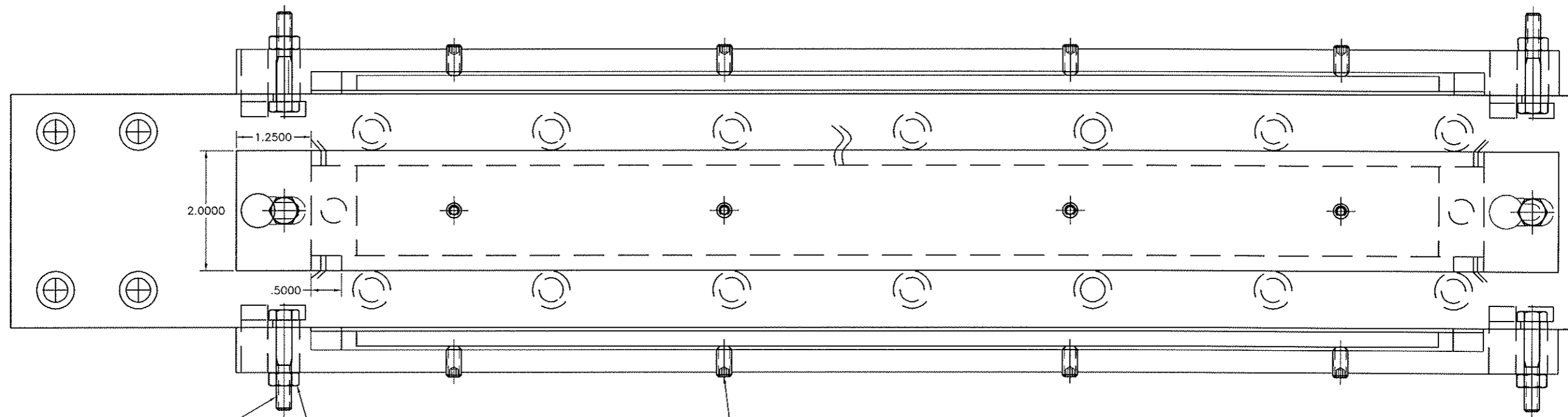

HEX BOLT - UNC (REGULAR THREAD - INCH)
ANSI/ASME B18.2.1 - 1/4 - 20 - 1 1/2

HEX NUT ANSI B18.2.2 - 1/4 - 20

HEXAGON SOCKET SET SCREW - FLAT POINT
ANSI B18.3 - 1/4 - 20 x 0.51

TSU SENIOR PROJECTS			
SIZE	FSCM NO.	DWG NO.	REV
SCALE	CD & ZM		SHEET 3-4

FNAME

REVDATE

USER

REVISIONS				
ZONE	REV	DESCRIPTION	DATE	APPROVED

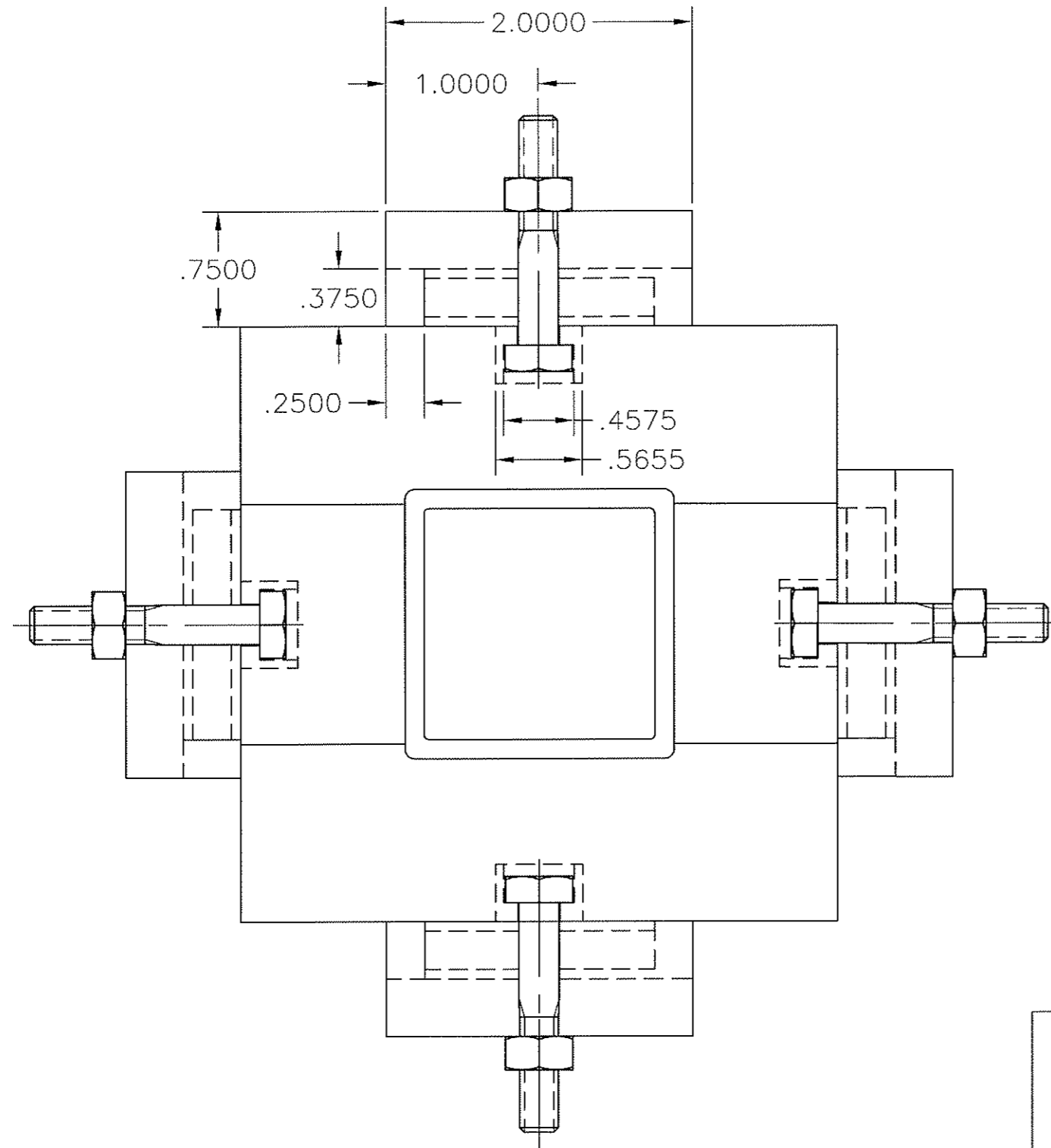

TSU SENIOR PROJECTS			
FIBERGRATE COMPOSITE STRUCTURES INC PULTRUSION HEATER COVERS			
SIZE	FSCM NO.	DWG NO.	REV
SCALE	CD & ZM	SHEET	4-4

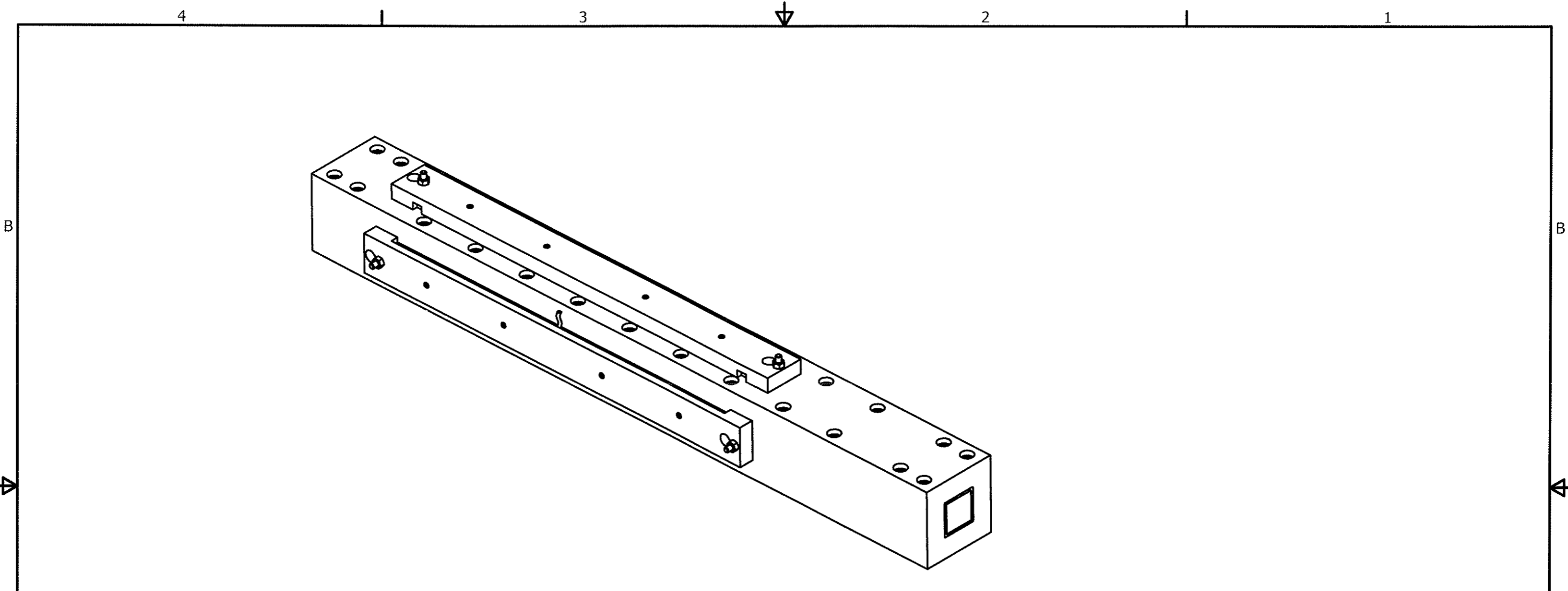

DRAWN	st_zmontgome	4/29/2010	TSU SENIOR PROJECTS		
CHECKED					
QA			FIBERGRATE COMPOSITE STRUCTURES INC PULTRUSION HEATER COVERS		
MFG					
APPROVED					
			SIZE	DWG NO	REV
			B	ASSEMBLY	
			SCALE	CD & ZM	SHEET 1 OF 1

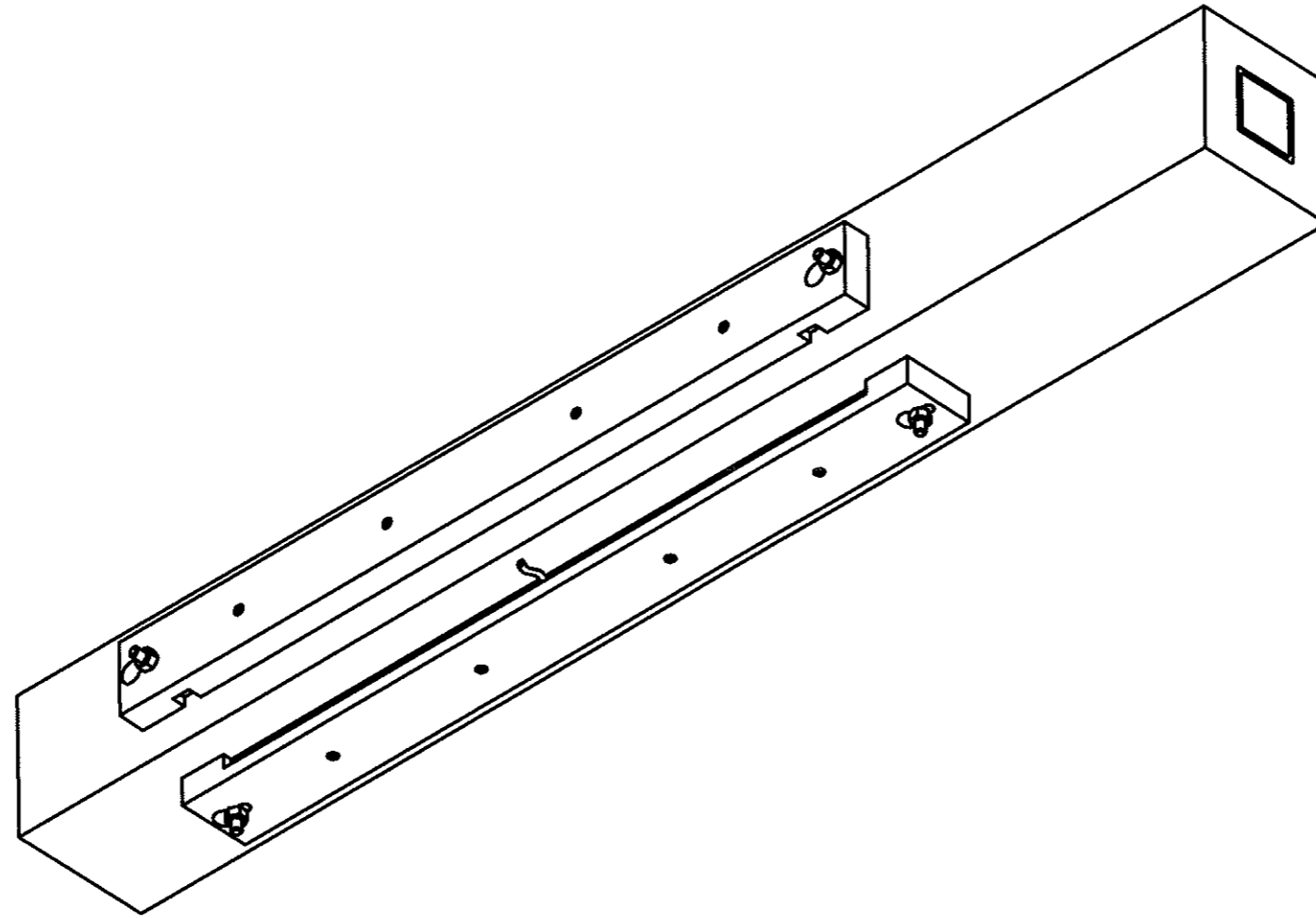

DRAWN	st_zmontgome	4/29/2010	TSU SENIOR PROJECTS	
CHECKED				
QA			TITLE FIBERGRATE COMPOSITE STRUCTURES INC PULTRUSION HEATER COVERS	
MFG				
APPROVED				
SIZE	B	DWG NO	ASSEMBLY	REV
SCALE		CD & ZM	SHEET 1 OF 1	

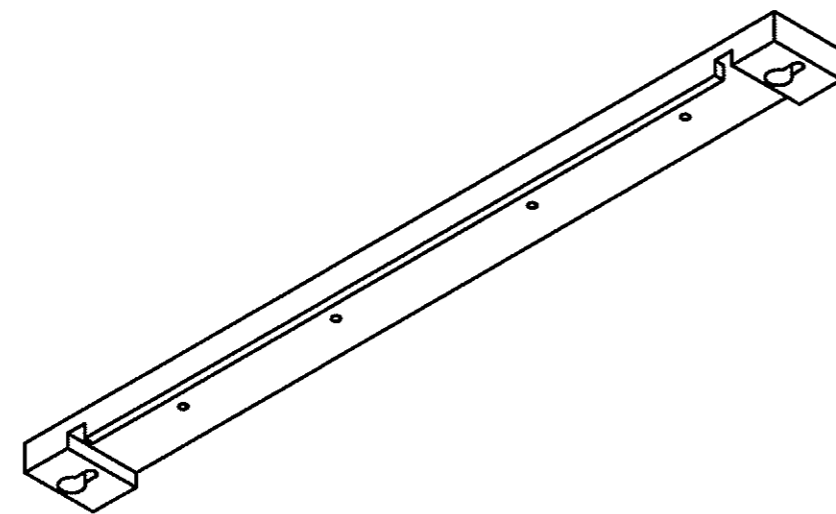
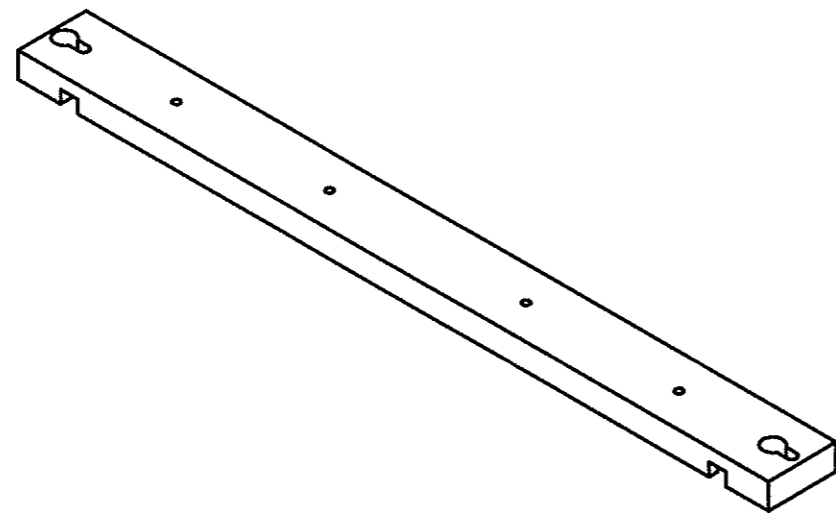

DRAWN	st_zmontgome	4/29/2010	TSU SENIOR PROJECTS		
CHECKED					
QA			TITLE FIBERGRATE COMPOSITE STRUCTURES INC PULTRUSION HEATER COVERS		
MFG					
APPROVED					
			SIZE	DWG NO	REV
			B	HEATER CLAMP	
			SCALE	CD & ZM	SHEET 1 OF 1

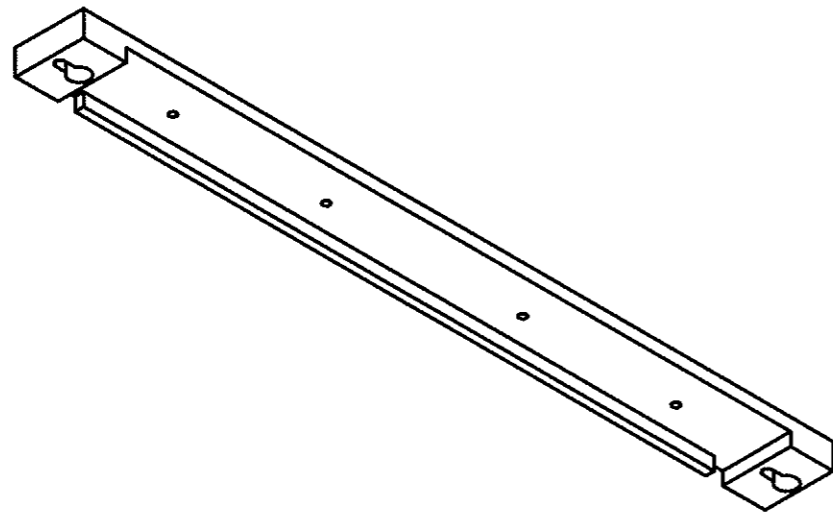
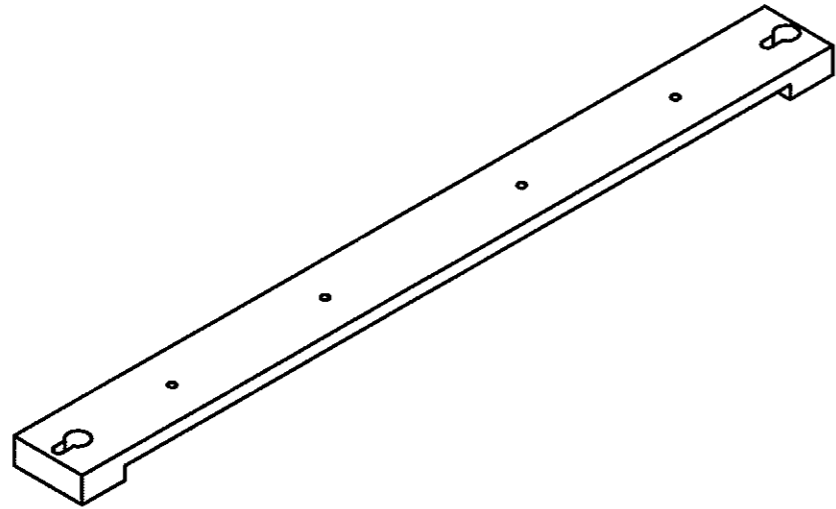

DRAWN st_zmontgome	4/29/2010	TSU SENIOR PROJECTS		
CHECKED				
QA		TITLE FIBERGRATE COMPOSITE STRUCTURES INC PULTRUSION HEATER COVERS		
MFG				
APPROVED				
		SIZE B	DWG NO	REV
			HEATER CLAMP	
		SCALE	CD & ZM	SHEET 1 OF 1