

Fibergrate Clip Drilling Machine

Project lead:

David Scott Frank

Members:

Jordan Lowe

Kyle Piercefield

Submitted for partial fulfillment of requirements for IT 495 senior projects class

Engineering Technology Department

Tarleton State University

Date: 4-30-2010

Project Acceptance Page

Fibergrate Clip Drilling Machine

David Scott Frank

Jordan Lowe

Kyle Piercefield

The following affirm that the project deliverables meets the needs of our customer and was accomplished by the project team:

Industrial Sponsor:

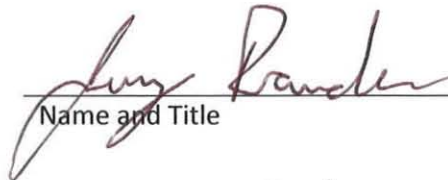
Name and Title _____ Date 5/11/2010

Faculty Mentor:

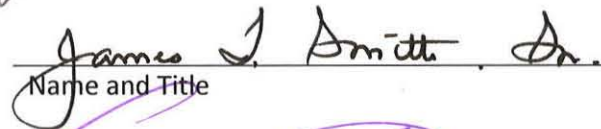
Name and Title _____ Date 5/11/2010

Department Approval:

Name and Title _____ Date 5-11-2010

Project Leader:

Name and Title _____ Date 5-10-2010

Table of Contents

Executive Summary4

Business Case4

Current Process4

Project Scope and Goals5

Business Need6

Current State6

Project Scope and Goals7

Project Strategy8

Recommendations9

Deliverables9

Project Cost9

Return on Investment10

Executive Summary

Business Case

Fibergrate has developed a need for an automated solution to drilling structural connection clips. The current machine does not function on a satisfactory level, and has resulted in an increased amount of user interaction to create the clips. This increase in user interaction has increased the cost of the parts and put a strain on the other activities of the worker. The parts are not of high enough volume to justify a full-time position, so any man-hours added because of these products are in addition to regular duties.

Current Process

The current process requires 40hrs of user interaction per month. Incoming lengths of pultruded fiberglass angle are placed on a saw and cut into desired length for desired product. The undrilled clips are then transported to the drilling station. The clips are hand placed in pairs into a machine that then drills the holes. The parts are removed, flipped and reinserted into the machine to drill the other side of the parts. Upon completion of drilling operation, the drilled holes in the clips are sealed by hand at a sealing location. The clips are then transported by cart to a shelf where they are stacked and placed in inventory. The current labor cost is \$1460/month. The purpose of this project is to design a machine that will replace the existing machine and method in order to reduce operator interaction.

Project Scope and Goals

Senior Design Team consists of Tarleton State Engineering Technology Students and has been contracted by Fibergrate to design a solution to improve the current drilling process of the structural connection clips. The TSU senior design team will design a clip-drilling machine with the purpose of replacing the existing machine with the capability to run the three highest volume parts and reduce operator interaction. The machine is not to require more space than the machine being replaced. A proposal will be provided by April 30, 2010 for a machine that will create catalog parts with adequate dust control. The proposal will consist of all information (parts, materials, and costs) required for construction. All CAD files necessary for construction will be provided with detail dimensions.

Business Need

Current State

Fibergrate is a leading provider of fiberglass products. As Fibergrate has continued to succeed with their structural products, the need for connection clips has increased. A point has been reached where too much user interaction is needed and is keeping the creation of the clips from being cost effective. The volume of the clips needed does not justify high automation costs. The clips do not generate a profit but must be provided as part of a structure solution for the customer. All of the connection clips are currently manufactured by hand. Fibergrate has stressed to the TSU senior design team that what is needed is not increased capacity or volume but reduced user interaction. A worker is being allocated to the clip process on top of their regular duties. After analyzing the amount of time that was consumed by the clip process, it is necessary to provide extra attention to this area.

The clip-drilling process is currently manually performed. A pultruded angle stock is cut to desired dimensions and then transferred to the clip table. An employee loads and clamps two clips to the X-Y table. After measuring and marking the dimensions of the holes necessary to be drilled in the clips, the employee drills one side of the clips. Removing the clips from the table and rotating to the opposite side, the clips are braced to the table and drilled again. This time consuming process will be shortened dramatically with an automated system.

When finished with the design and research the TSU senior design team will provide Fibergrate with detailed drawings, bill of materials list, part catalog necessary for controller and a project portfolio that will analyze the following:

- Design of an automated control with drilling capabilities and detailed dimensions.
- Cost of the machine replacing the existing control and the amount of human interaction that is reduced.
- Catalog of parts necessary to construct automated controller.

- The project portfolio will cover and consist of current processes, scope, goals, and future solutions to Fibergrate's clip-drilling process.

Project Scope and Goals

The TSU senior design team will design a clip-drilling machine with the purpose of replacing the existing machine and reducing operator interaction. The machine is not to require more space than the machine being replaced. A proposal will be provided by April 30, 2010 for a machine that will create catalog parts with adequate dust control. The proposal will consist of all information (parts, materials, and costs) required for construction. All CAD files necessary for construction will be provided with detail dimensions.

The main objective is to reduce human interaction on a process that is necessary for construction of structural connection products or "clips". Reducing interaction will allow the employee to be able to diversify their time to other processes. This diversification will dramatically increase the efficiency of the operations.

Project Strategy

The scope of this project consists of only the clip-drilling process, handling and cutting of the clips were not required as part of the solution provided by the TSU senior design team. To reduce user interaction for Fibergrate the TSU senior design team has designed an automated machine that will drill the clips with minimal user interaction. The machine does not require more space than the machine being

replaced. The machine allows Fibergrate to be capable of producing connection clips more efficiently. The clips are a minimal piece to Fibergrate's structural production; however reducing user interaction will enable more time to be spent on other, more vital products. All of this was considered when designing a solution for Fibergrate.

The primary strategy for our design was to find off-the-shelf products created for similar uses to our project. Research about the process was conducted and different vendors were identified, contacted and products evaluated. The project took many different turns throughout its course. Some of the first designs involved robots and Vertical Machining Centers. Because of cost and overly complex design, the early designs slowly gave way to more simplistic modular automation. The focus was primarily placed on finding prefabricated solutions because doing so eliminates much risk of system design. By ordering a system that handles most of the complex operations needed, instead of creating the system from scratch, we manage to achieve a solution that will arrive at the plant mostly ready to operate. Some of the limitations to designing a home-grown solution from scratch are that the components may not be designed to work together, and much more work is needed in designing fixtures and mounting brackets to make sure everything fits together. As an added factor, the reliability of the custom machine is suspect and there is little vendor support. Therefore, any problems encountered with a solution designed from scratch would be amended with nothing short of part replacement. All of these are reasons why we decided to try and find the majority of our system prefabricated. We believe it will prove more valuable in the long run.

Recommendations

While an automated system will reduce user interaction required to drill the clips, the overall process can still be improved. A more ideal system would be to consolidate the drilling and cutting

processes into one location to avoid transfer time and WIP. A similar table to the one suggested in this report could be used to drill longer stock pieces (instead of shorter blanks) and a vertical saw could be mounted to the end of the table where the drilled and cut clips can wait for sealing. This would remove the time taken to wait for the angle to be cut into clips then transferred to the drilling location.

Consolidating the cutting of the clips with the drilling of the clips will streamline the overall process and increase manufacturing efficiency.

The solution provided in this document has two different options. Option 1 denotes the k2 machine all components for part movement and control as well as two (2) 18k rpm routers to be mounted independently on the Z axes. Option 2 is the same as Option 1 without the routers. This makes the cost significantly lower but also increases the risk and complexity of the machine. It is our recommendation that Option 1 be used both for its out-of-the-box simplicity and lower risk.

Deliverables

Fibergrate will receive the following:

- Design of a new machine.
- All drawings needed to fully describe design.
- A list of parts/items required creating design.
- A cost summary of all components.
- Final project report denoting project details.

Project Cost

Expense	Original Budget	Current Budget	Est. to Complete
Option 1	\$10000		13994.52
Option 2			7294.52
Total	\$10000		

Return on Investment

The current process cost is calculated using \$36.50/hr for labor. At 40hrs/month this adds up to \$1460.00 per month and \$17520.00 per year. Our solution will save \$1277.50 per month over the current process cost. With our solution cost being \$13994.52, it will reach total payoff in 11 months.

Bill of Materials

Part	Part Number	Quantity	Company	Price	Total
Cylinder	NCAIKL200-2400J	1	SMC	\$135.00	\$135.00
Valve Body	VQ520-5H-04TN	3	SMC	\$152.10	\$456.30
Valve Manifold	VV5Q5I-0303NLUI	1	SMC	\$241.70	\$241.70
Stopper Cylinder	MGPM32N-50	1	SMC	\$275.85	\$275.85
Cherry Electrical Switch	GPTCRM11	1	Allied Electronics	\$8.51	\$8.51
Air Clamp	CL-400-PTC	1	Carr Lane	\$93.30	\$93.30
K2 CNC Machine	KG-1414	1	K2	\$12,494.95	\$12,494.95
	ROUTERS	1	K2	\$3700	\$-3700
Vertical Magazine	-	1	Metals Depot	\$105.48	\$105.48
PLC	JZ10-11-T40	1	Unitronics	\$199.00	\$199.00
Power Supply	PSP24-024S	1	Unitronics	\$57.00	\$57.00
Communication Cable	RS232-CB1	1	-	IN HOUSE	-
Dust Hood	460	1	Peachtree Woodworking	\$10.99	\$10.99
Dust System	-	1	-	IN HOUSE	-
Rail	-	1	Metals Depot	\$51.44	\$51.44
				TOTAL	\$14,129.52
				MODIFICATION	\$10,429.52

Return on Investment

Current state:

40 hours X \$36.50= \$1460 per month. (Clips are drilled once a month)

\$1460 X 12 months= \$17520 a year.

Our solution:

5 hours X \$36.50= \$182.50 per month

\$182.50 X 12 months= \$2190 a year.

\$17520-\$2190= \$15330 per year in savings.

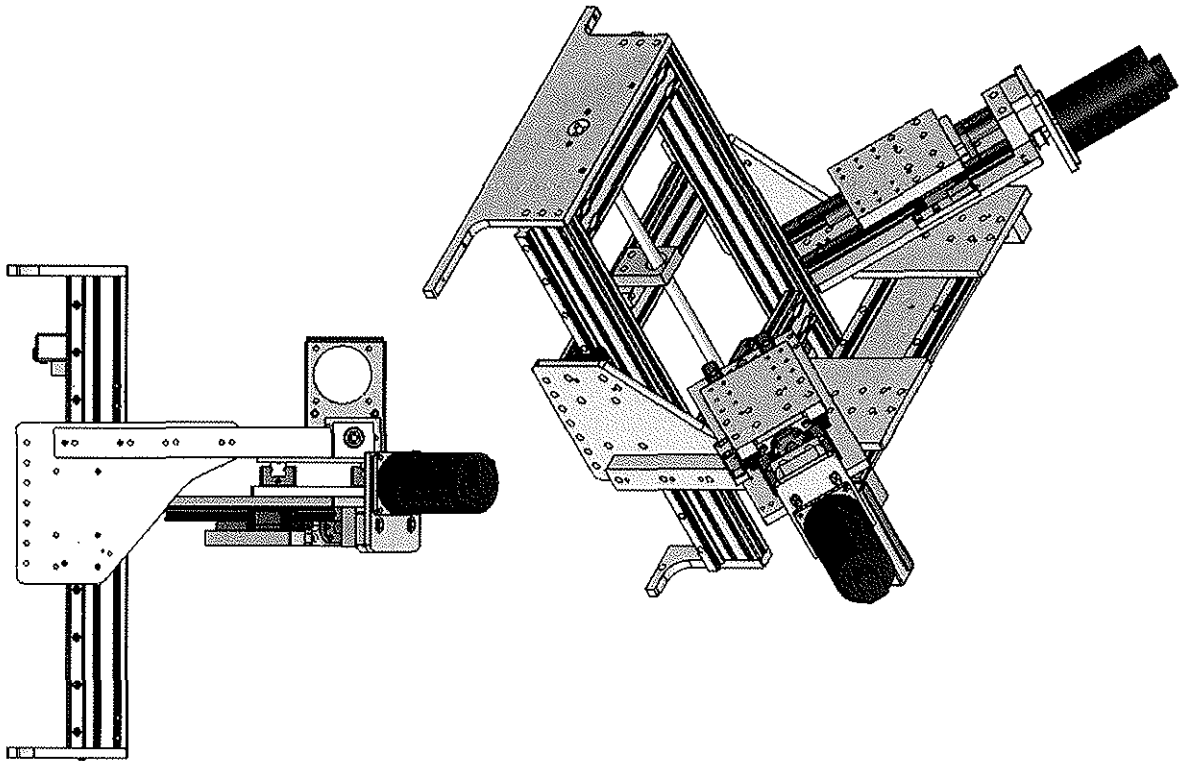
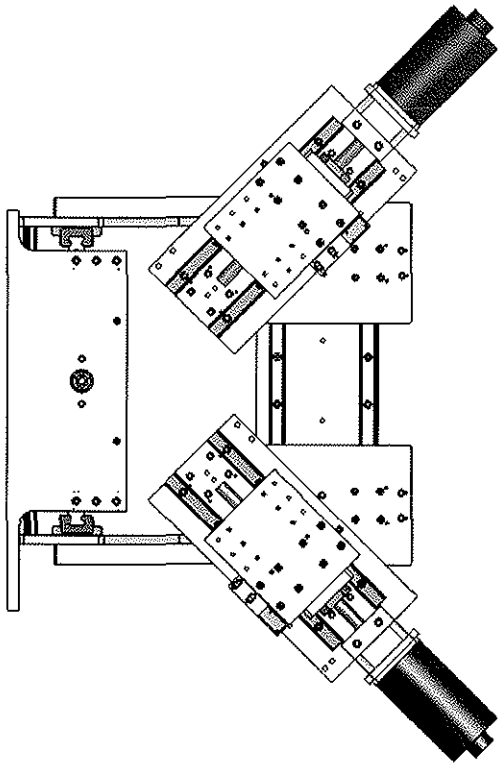

Threaded Rods and Studs



Part Number: **98790A033**

\$2.18 Each

Material Type	Steel
Finish	Plain
Grade/Class	Not Rated
Type	Fully Threaded Rods and Studs
Steel Type	General Purpose Steel
Thread Direction	Right Hand Thread
Inch Thread Size	1/2"-13
Overall Length	24"
Rockwell Hardness	Minimum B61
Minimum Tensile Strength	53,000 psi
Thread Fit	Class 2A
Specifications Met	Not Rated
Notes	Length is measured from end to end.

Roller Chain Sprockets

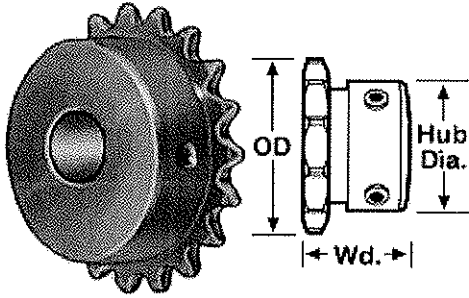

Part Number: **2737T107**

\$6.08 Each

Type	Drive
For Chain Number	ANSI 25
System of Measurement	Inch
Pitch	1/4"
Bore	Finished
Finished-Bore Type	Includes 2 Set Screws
Bore Size	1/2"
Shape	Single Strand With Hub
Number of Teeth	14
ANSI Keyway Size (Width x Depth)	None
Outside Diameter	1.25"
Width	1/2"
Hub Diameter	13/16"
Material	Steel

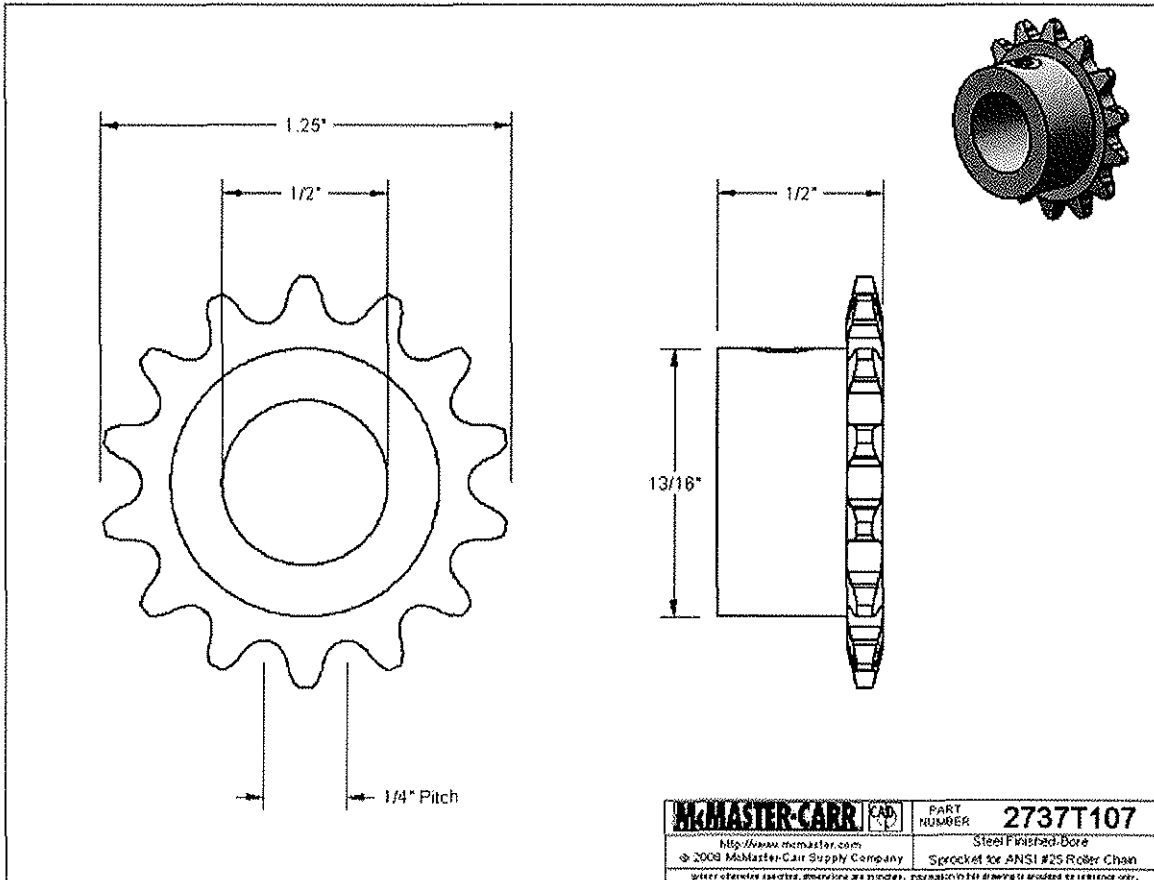

McMASTER-CARR <small>CAD</small>	PART NUMBER 2737T107
<small>http://www.mcmaster.com</small>	Steel Finished Bore
<small>© 2008 McMaster-Carr Supply Company</small>	Sprocket for ANSI #25 Roller Chain
<small>Unless otherwise specified, dimensions are in inches. All drawings are subject to change without notice.</small>	

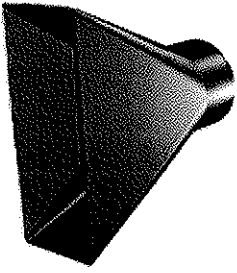

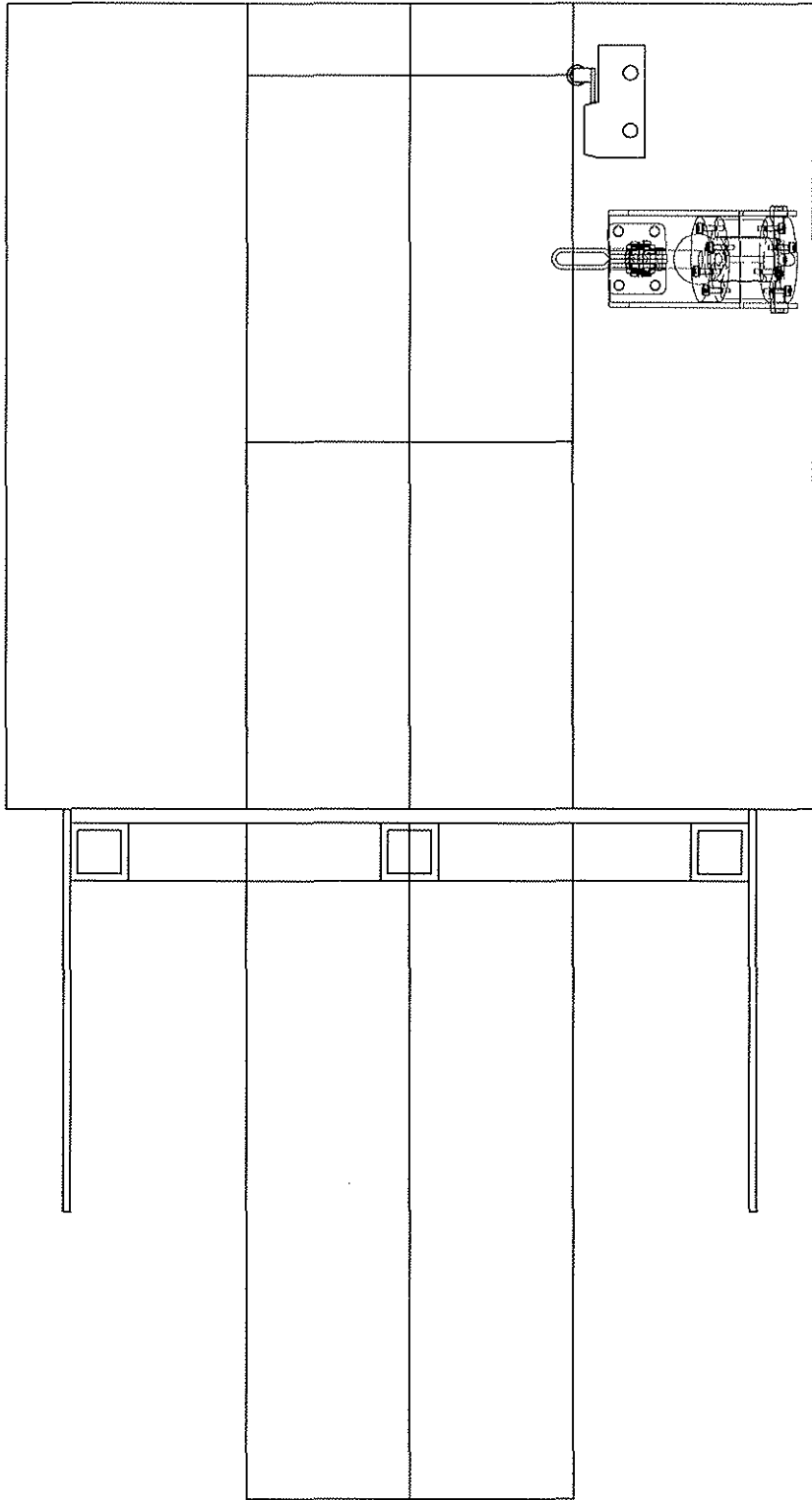

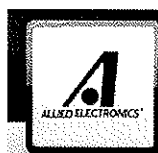

TECHNICAL SUPPORT: [See our product selection and technical assistance](#)

Country: US | My Account | Login | Cart (0)

[Home](#) | [Products](#) | [Services](#) | [Catalog](#) | [Customer Service](#) | [About Us](#)

need help? call (866) 433-5722

[Search](#)

Cherry Electrical GPTCRM11

[Products](#) > [Sensors, Switches & Relays](#) > [Switches](#) > GPTCRM11

[View More Cherry Electrical Switches >>](#)

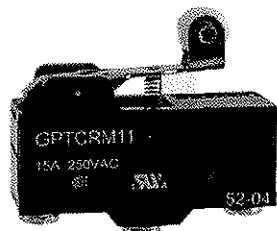

CHERRY

Switch, Snap Action, SCREW Terminals, SPDT, 15A 125VAC/15A 250VAC

Mfr. Part#: GPTCRM11

Allied Stock#: 908-0046

Quantity:

[Add to Cart](#)

[View larger image](#)

Customer Rating



0 out of 0

[Be the first to review this product](#)

Documents

[Datasheet](#)

[Catalog Page #978](#)

Notes

RoHS Compliant part

Pricing (USD) & Availability

Standard Pricing

\$10.67 (Each)

1 - 24	\$10.670
25 - 49	\$8.550
50 - 99	\$6.970
100 - 249	\$6.600
250+	\$6.180

Availability

514 can ship immediately. Request Lead Time

Min. Order QTY: 1 | Multiples of: 1

[Overview](#) [Specs](#) [Reviews \(0\)](#) [Similar Products](#)

Actuator Type	: Lever
Body Style	: Ultra-Miniature
Contact Form	: SPDT
Current, Rating	: 15/0.5 AAC/ADC
Dielectric Strength	: 1000 VAC
Force, Operating	: 5.6 Oz. (Max.)
Material, Casing	: Phenolic
Mounting Hole Size	: 0.14 "
Number of Poles	: 1
Operation	: Snap Action
Special Features	: Heavy Duty
Temperature Rating	: -20 to +85 °C
Termination	: Screw
Type	: Basic
Voltage, Rating	: 250 VAC/VDC

People Also Bought

You may also want to consider these products other people have purchased.

[Sensors, Switches & Relays > Sensors](#)



Omron Automation
Sensor; NPN; Slot Sensing Mode; Photomicro; 3.6 mm; Infrared Light; 5 to 24 VDC

Is this product relevant? [Yes](#) | [No](#)

\$21.42 (Each) [Add to Cart](#)

[Sensors, Switches & Relays > Switches](#)



Cherry Electrical
Switch, GEN PURP, SP, 1.391" Roller STD RAT, 15A@125/250VAC; 3/4HP@125VAC; 1

Is this product relevant? [Yes](#) | [No](#)

\$4.15 (Each) [Add to Cart](#)



Cherry Electrical
Switch, Pushbutton; Panel Mount; DPDT; 10 A; 125/250 VAC; 680 g; Thermo. Poly.

Is this product relevant? [Yes](#) | [No](#)

\$5.78 (Each) [Add to Cart](#)



Cherry Electrical
Switch, Miniature LIGHT AND Standard FORCE, QC Terminal

\$2.93 (Each) [Add to Cart](#)

Is this product relevant? [Yes](#) | [No](#)



Cherry Electrical
Switch, Snap Action, 20 Amps, 125VAC, 6.3 Oz. Max Operating Force, Screw Mount

\$10.92 (Each) [Add to Cart](#)

Is this product relevant? [Yes](#) | [No](#)



Cherry Electrical
Switch, Snap Action, SCREW TerminalS, SPDT, 15A 125VAC/15A 250VAC

\$8.53 (Each) [Add to Cart](#)

Is this product relevant? [Yes](#) | [No](#)



Cherry Electrical
Switch, Snap Action, SCREW TerminalS, SPDT, 15A 125VAC/15A 250VAC

\$17.79 (Each) [Add to Cart](#)

Is this product relevant? [Yes](#) | [No](#)



Cherry Electrical
Switch, Snap Action, HEAVY DUTY, 15 AMPS, SCREW TerminalS

\$13.02 (Each) [Add to Cart](#)

Is this product relevant? [Yes](#) | [No](#)



Cherry Electrical
Switch, Snap Action, SCREW TerminalS, SPDT, 15A 125VAC/15A 250VAC

\$7.83 (Each) [Add to Cart](#)

Is this product relevant? [Yes](#) | [No](#)

Test Connectors > Connectors



Pomona Electronics
Banana Jack; Banana Jack; 15 A; Black; Beryllium Copper; 5000 Vrms (Max.)

\$15.15 (Pack) [Add to Cart](#)

Is this product relevant? [Yes](#) | [No](#)

* These are not Recommended Accessories and may not be compatible with the primary product.

[Terms & Conditions](#)
[Privacy](#)
[Security](#)
[Shipping Info](#)
[Legal](#)

[About Us](#)
[Allied History](#)
[Press Room](#)
[Careers](#)
[Quality](#)

[Customer Service](#)
[Contact Us](#)
[Tech Support](#)
[Services](#)
[Returns](#)

[Order Status](#)
[Quick Order](#)
[Supplier Line Card](#)
[Allied Labs](#)
[Order Catalog](#)
[Site Map](#)





MANUFACTURING CO.
4200 Carr Lane Ct., P.O. Box 191970
St. Louis, Missouri 63119-7970 USA
Phone: 314-647-6200, FAX: 314-647-5736
Web Site: www.carrlane.com

en_1384

AIR-POWERED CLAMPS

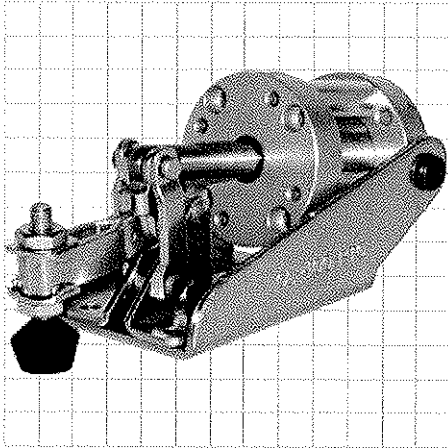

CL-400-PTC

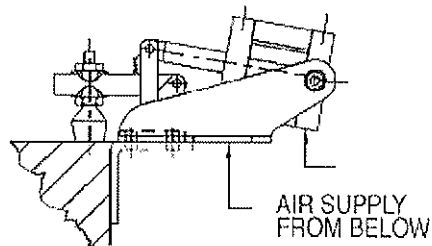
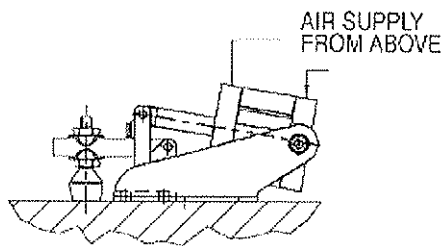

100 Lbs Holding Capacity

FEATURES: Super-compact air clamp for applications where space is at a premium. Similar to a vertical-handle hold-down clamp, except operated by an air cylinder instead of by hand. Toggle linkage provides high holding capacity and insures positive mechanical locking even if air pressure fails. Open arm provides adjustable spindle location. Arm opens 100°. Made in USA.

OPTIONAL POSITION SENSING: These clamps are optionally available with an air cylinder that has a magnetic piston ring for position sensing. Order Hall-effect switch separately (see Air Accessories).

MODELS AVAILABLE (STEEL):

CL-400-PTC	Open Arm
CL-400-PTC-MPD	Open Arm, Position Sensing

AIR CYLINDER: 3/4" bore, double acting, #10-32 ports. Buna-N seals for -20° to +200°F operating temperature. High-temperature viton seals are available by special order (+400°F maximum). 100-psi maximum input air pressure exerts 100 lbs maximum clamping force at center of arm.

ACCESSORIES: Supplied with #10-32 flat-cushion spindle CL-316112-FC and (2) CL-3166-TW flanged washers. An optional bracket for side mounting is also available (CL-400-PCBR).

MATERIAL: Clamp body and base > 1008, 1010, and/or 1018 steel, zinc plated clear chromate. Air Cylinder > Steel and aluminum. Rivets > 400-series stainless. DFARS and RoHS compliant.

To order fittings for #10-32 ports, See:
[Tubing Connector](#)
[Banjo Elbow](#)
[Branch Tee](#)

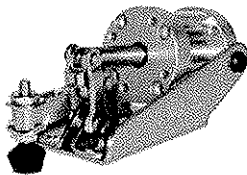

Also available with position sensing.

CL-400-PTC-MPD



Peachtree Woodworking Supply Inc.
 3250 Oakcliff Ind. St., Atlanta, Georgia 30340 Ph: (770) 458-5539 Fax: (770) 458-228

Order Central Shopping Basket 
 for the following Web sites:

Ptreeusa.com Justfreud.com JUSTCLAMPS.COM

NoSawdust.com Allbandsawblades.com ttrackusa.com

Items 1 | Sub Total \$10.99 Checkout

Basket

If you have a key code, please enter it.

Submit

[click here to estimate shipping cost.](#)

Remove	Qty	Description	Total
<input type="checkbox"/>	<input type="text" value="1"/>	BLACK DUST HOOD (NO GRATE) Item: 460 Price: \$10.99	\$10.99

[Update Basket](#) | [Empty Basket](#)

Subtotal: \$10.99

CONTINUE SHOPPING

SHIP TO MULTIPLE ADDRESS

PROCEED TO CHECKOUT

From this central basket location you can view or check out your basket, or continue shopping at any of the web sites listed above.

You may add items to your basket from any of the web sites listed above and check out at this one convenient location.

[Home](#) | [New Customer](#) / [Registered Customers Login](#)

REV	DESCRIPTION	DATE	BY
A	REVISED SCHEDULE A	7/13	DC
B	SEE ECN 004	10/28	DC
C	ECN-14	12/2/90	
D	ECN-17	8/15/91	RC
E	ECN-37	2/9/93	JH

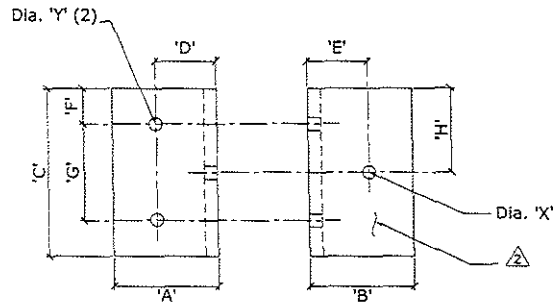

NOTES:

1. DEBURR AND SEAL ALL DRILL HOLES AND CUTS PER SPECS FGI 8-6,8-11,8-12 FGS 8-3,8-4
2. PREPARE THIS SURFACE FOR BONDING PER SPEC FGI 8-11 IF BONDING IS REQUIRED.

SCHEDULE A

ANGLE CLIP NUMBER	ANGLE CLIP MATERIAL	DIM A	DIM B	DIM C	DIM D	DIM E	DIM F	DIM G	DIM K	DIA X	DIA Y
AC3-01	3x3x3/8	3	3	4 1/2	1 3/4	1 3/4	7/8	2 3/4	2 1/4	9/16	7/16
AC3-02	3x3x3/8	3	3	3 1/4	1 1/2	1 3/4	5/8	2	1 5/8	9/16	7/16
AC3-03	3x3x1/4	3	3	4 5/8	1	2 1/8	1	2 5/8	2 5/16	7/16	7/16
AC3-04	4x4x3/8	4	4	6 1/2	1 1/2	2 3/4	1 1/4	4	3 1/4	9/16	9/16
AC3-05	3x3x1/4	3	3	4 5/8	1 3/8	2 1/8	1	2 5/8	2 5/16	7/16	7/16
AC3-06	3x3x3/8	3	3	3	1 1/2	1 1/2	3/4	1 1/2	1 1/2	7/16	7/16
AC3-07	3x3x3/8	3	3	4 1/2	1 1/2	1 1/2	7/8	2 3/4	2 1/4	7/16	7/16
AC3-08	4x4x1/2	4	4	4 1/2	1 1/2	1 1/2	7/8	2 3/4	2 1/4	9/16	9/16
AC3-09	4x4x1/2	4	4	6 3/8	2 1/2	2 1/2	1 11/16	3	3 3/16	9/16	9/16
AC3-10	3x3x3/8	3	3	6 3/8	1 3/4	1 3/4	1 11/16	3	3 3/16	7/16	7/16

SCHEDULE B

MATERIAL	ISOFR	VEFR
3x3x3/8 Ang.	1614400	161740
3x3x1/4 Ang.	1614350	161735
4x4x3/8 Ang.	1614500	161750
4x4x1/2 Ang.	1614510	161746

DRAWING TITLE STRUCTURAL CONNECTION DETAIL - TYPE 'AC3'			
SCALE N.T.S.	DATE 12/2/90	DRAWN R. BREWSTER	
DRAWING NUMBER B-AC3-0001		SHEET 1 of 1	

Fibergrate
Composite Structures
An Rpm Company

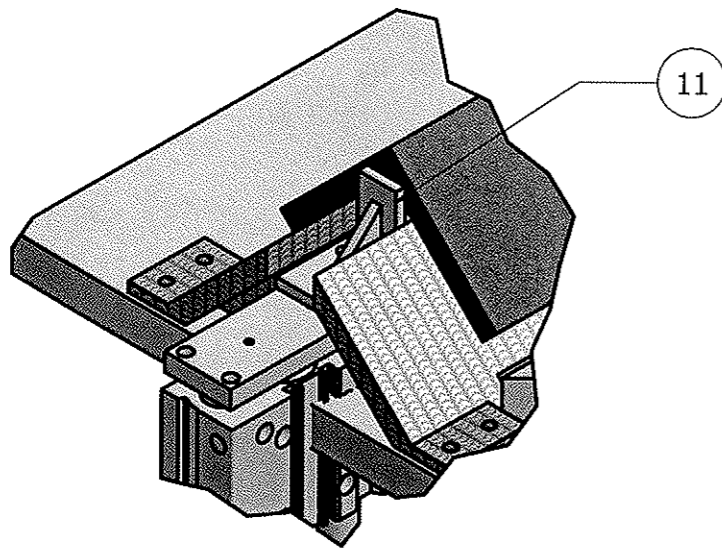

DETAIL A
SCALE 0.28 : 1

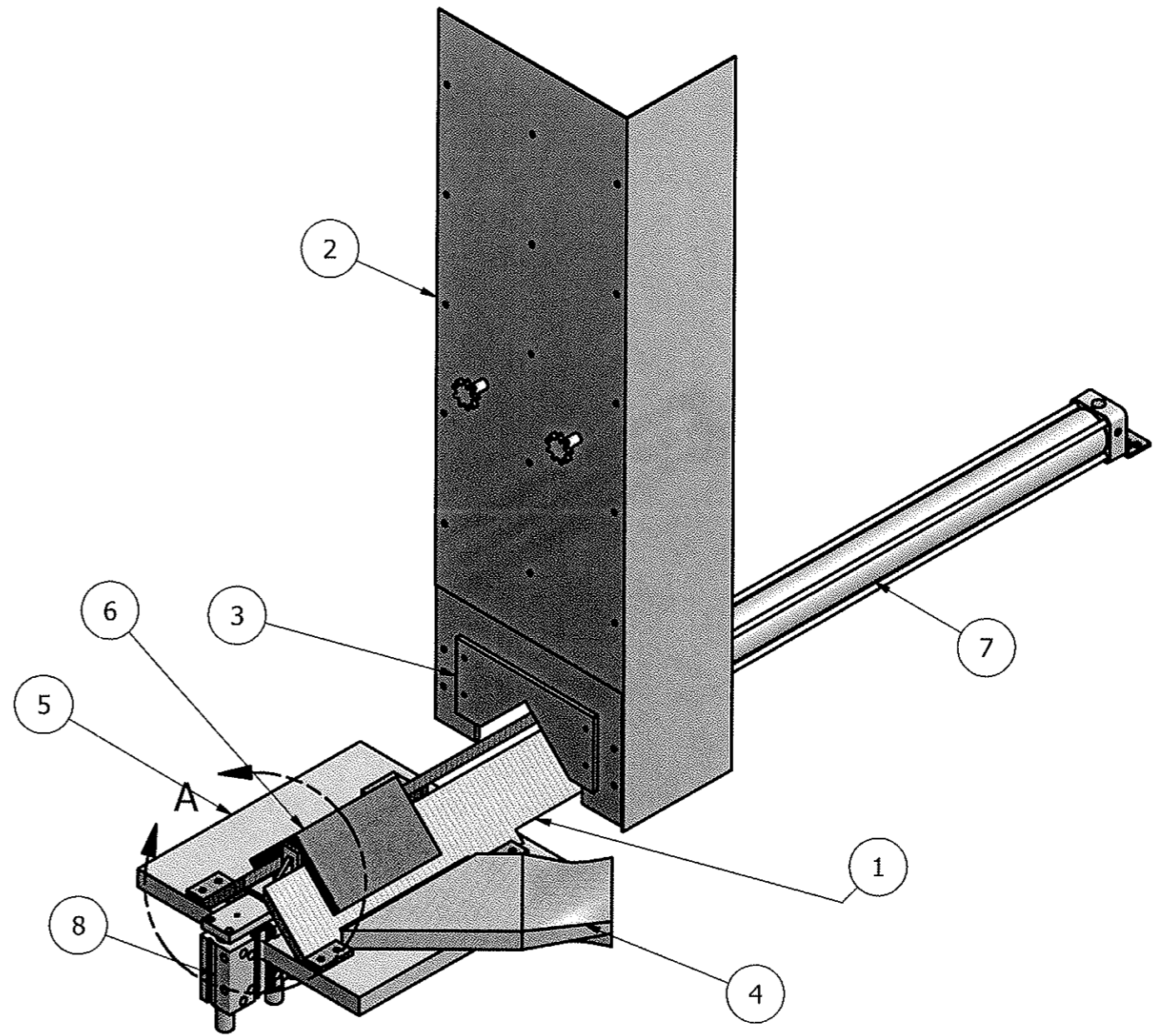

PARTS LIST

ITEM	QTY	PART NUMBER	DESCRIPTION
1	2	Clip Rail	
2	1	Vertical Magazine Shell	
3	2	Vertical Magazine Front Sliding Plate	
4	1	Dust Collector	
5	1	TableTop	
6	1	4x6.375 clip	
7	1	Feed Cylinder	
8	1	Dead Stop Cylinder	
9	1	Moving Part	
10	1	Stationary Part	
11	1	Dead Stop Flange	
13	2	Sprocket	

DRAWN st_dfrank	4/29/2010	TITLE		
CHECKED				
QA				
MFG				
APPROVED				
		SIZE B	DWG NO Total Automation	REV
		SCALE	SHEET 1 OF 1	

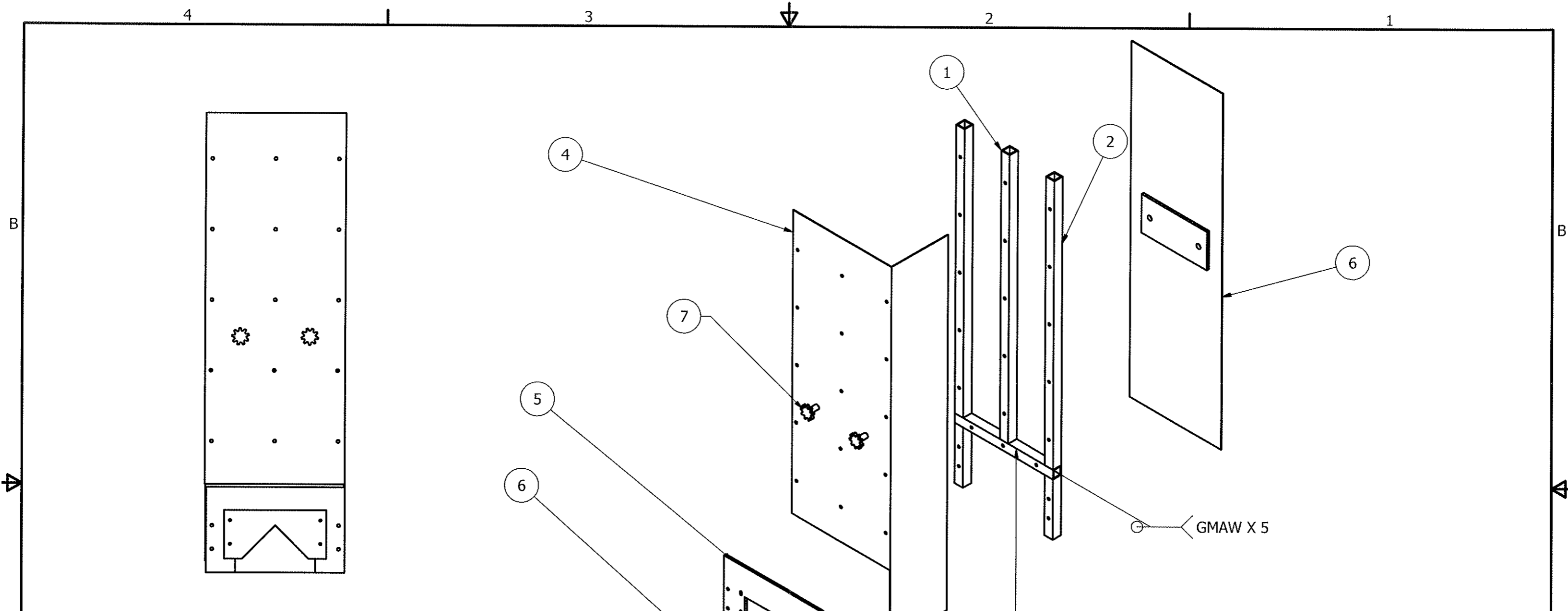

PARTS LIST			
ITEM	QTY	PART NUMBER	DESCRIPTION
1	1		Vertical Magazine Center Support Rails
2	2		Vertical Magazine Side Support Rails
3	1		Vertical Magazine Horizontal Supports
4	1		Vertical Magazine Shell
5	1		Vertical Magazine Front Stationary Plate
6	1		Vertical Magazine Front Sliding Plate
6	1		Back Plate
7	2		Sprocket

DRAWN D.S. Frank	4/26/2010	TSU Sr. Projects: Fibergrate Clip Drilling Machine	
CHECKED		TITLE	
QA			
MFG			
APPROVED			
		SIZE B	DWG NO Vertical Magazine
		SCALE	REV
		SHEET 1 OF 9	

NOTE: MATERIAL IS 1" SQ. TUBING

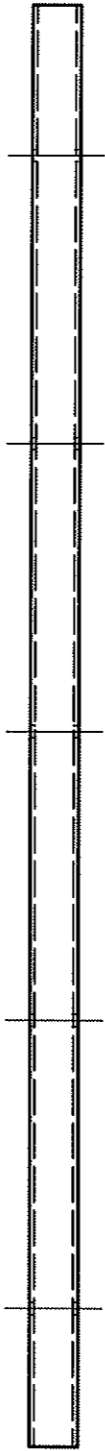
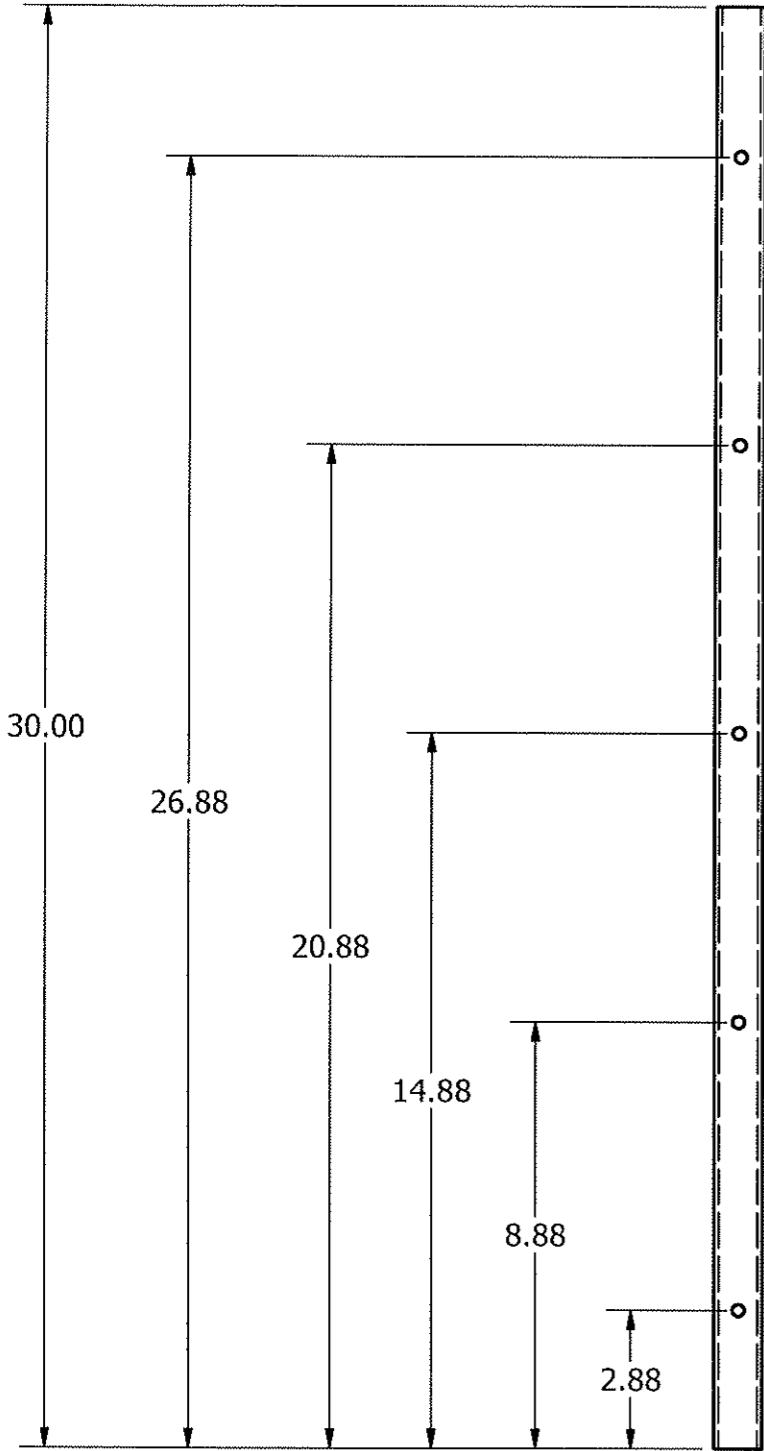

DRAWN D.S. Frank	4/26/2010	TSU Sr. Projects: Fibergrate Clip Drilling Machine		
CHECKED		TITLE		
QA		SIZE B		
MFG				
APPROVED				
		DWG NO	Vertical Magazine	REV
		SCALE	SHEET 2 OF 9	

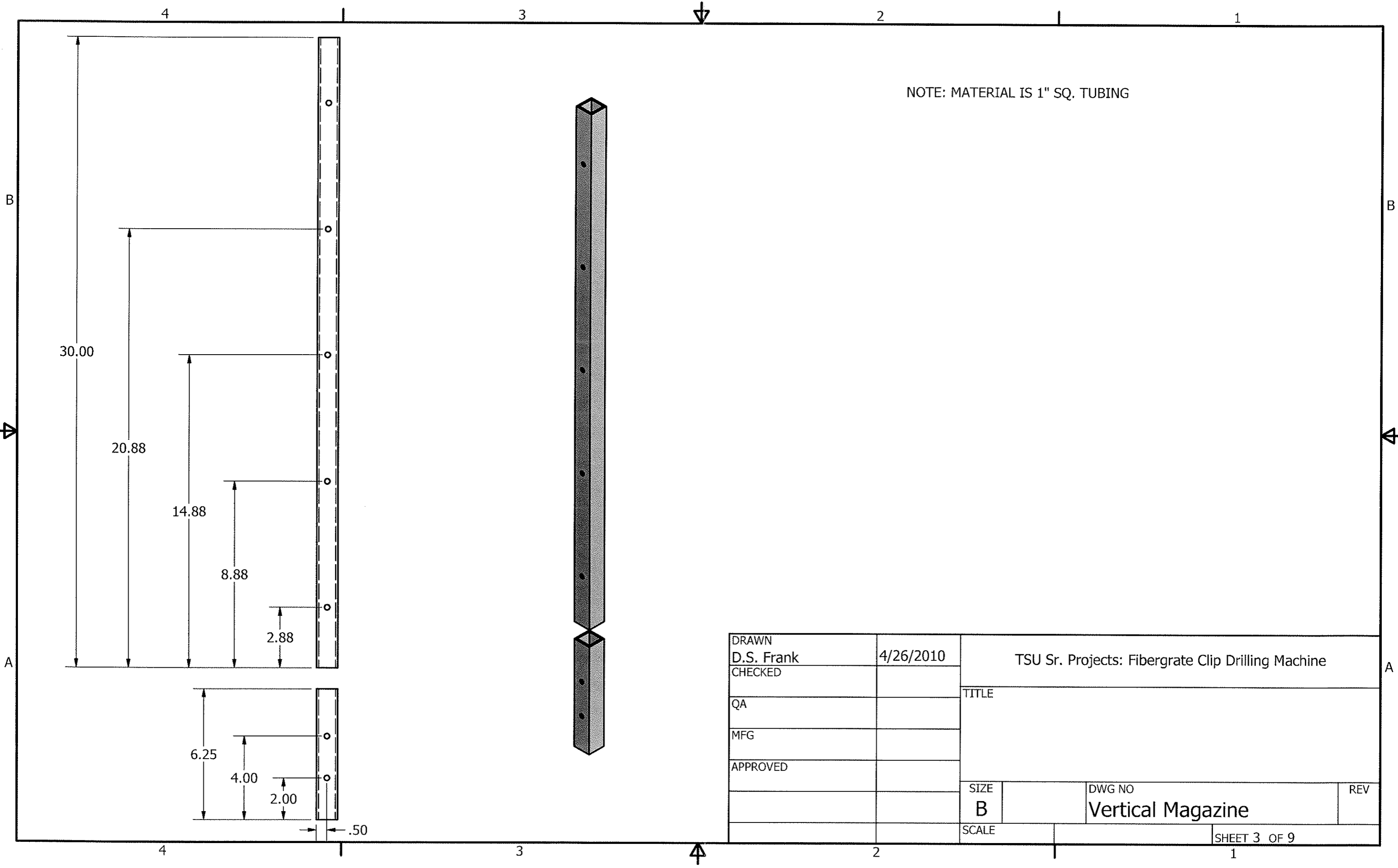

NOTE: MATERIAL IS 1" SQ. TUBING

DRAWN D.S. Frank	4/26/2010	TSU Sr. Projects: Fibergrate Clip Drilling Machine		
CHECKED		TITLE		
QA		TITLE		
MFG		TITLE		
APPROVED		TITLE		
		SIZE B	DWG NO Vertical Magazine	REV
		SCALE	SHEET 3 OF 9	

NOTE: MATERIAL IS 1" SQ. TUBING

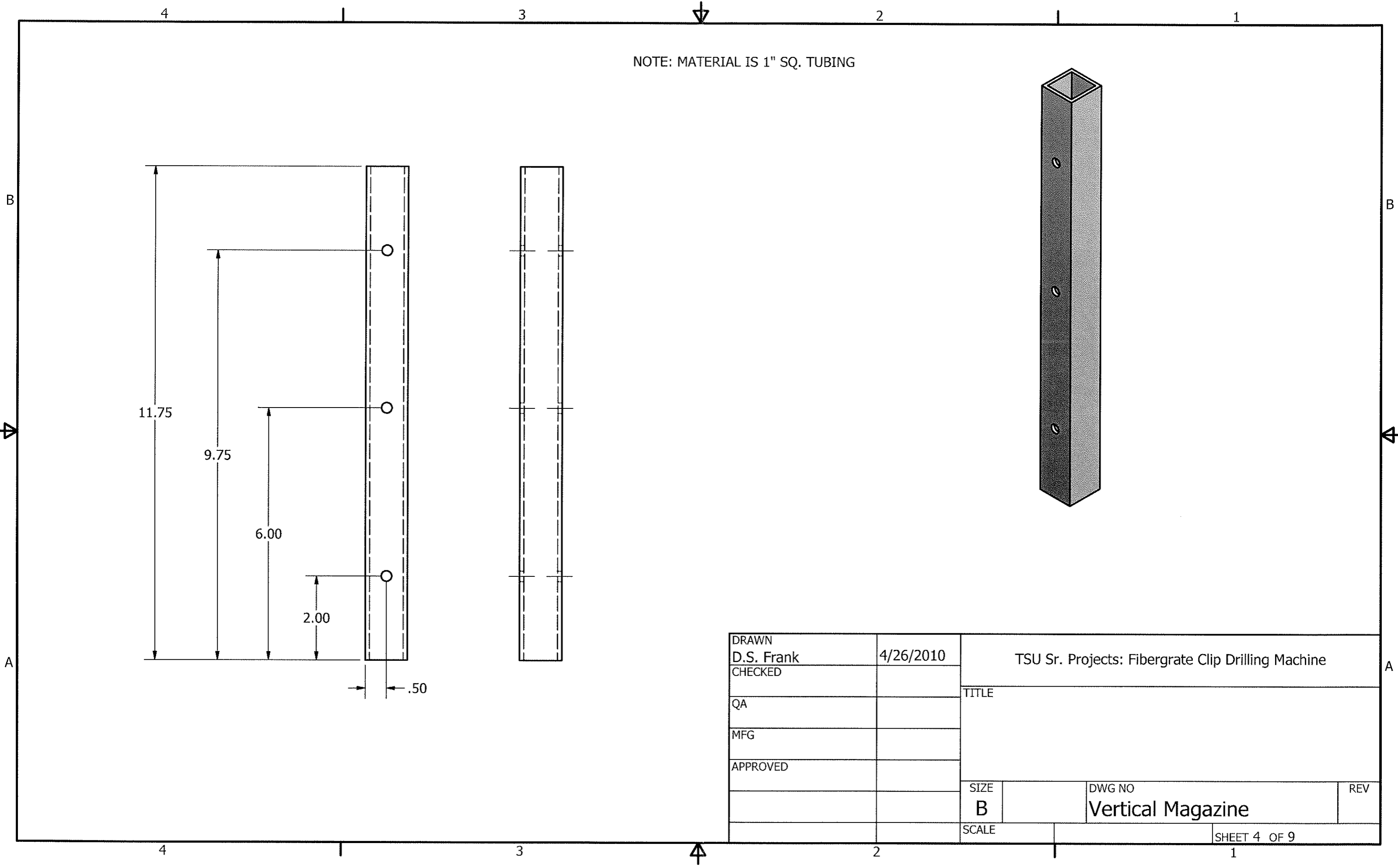

DRAWN D.S. Frank	4/26/2010	TSU Sr. Projects: Fibergrate Clip Drilling Machine		
CHECKED		TITLE		
QA				
MFG				
APPROVED				
		SIZE B	DWG NO Vertical Magazine	REV
		SCALE	SHEET 4 OF 9	

4

3

2

1

NOTE: MATERIAL IS 1/16" SHEET METAL

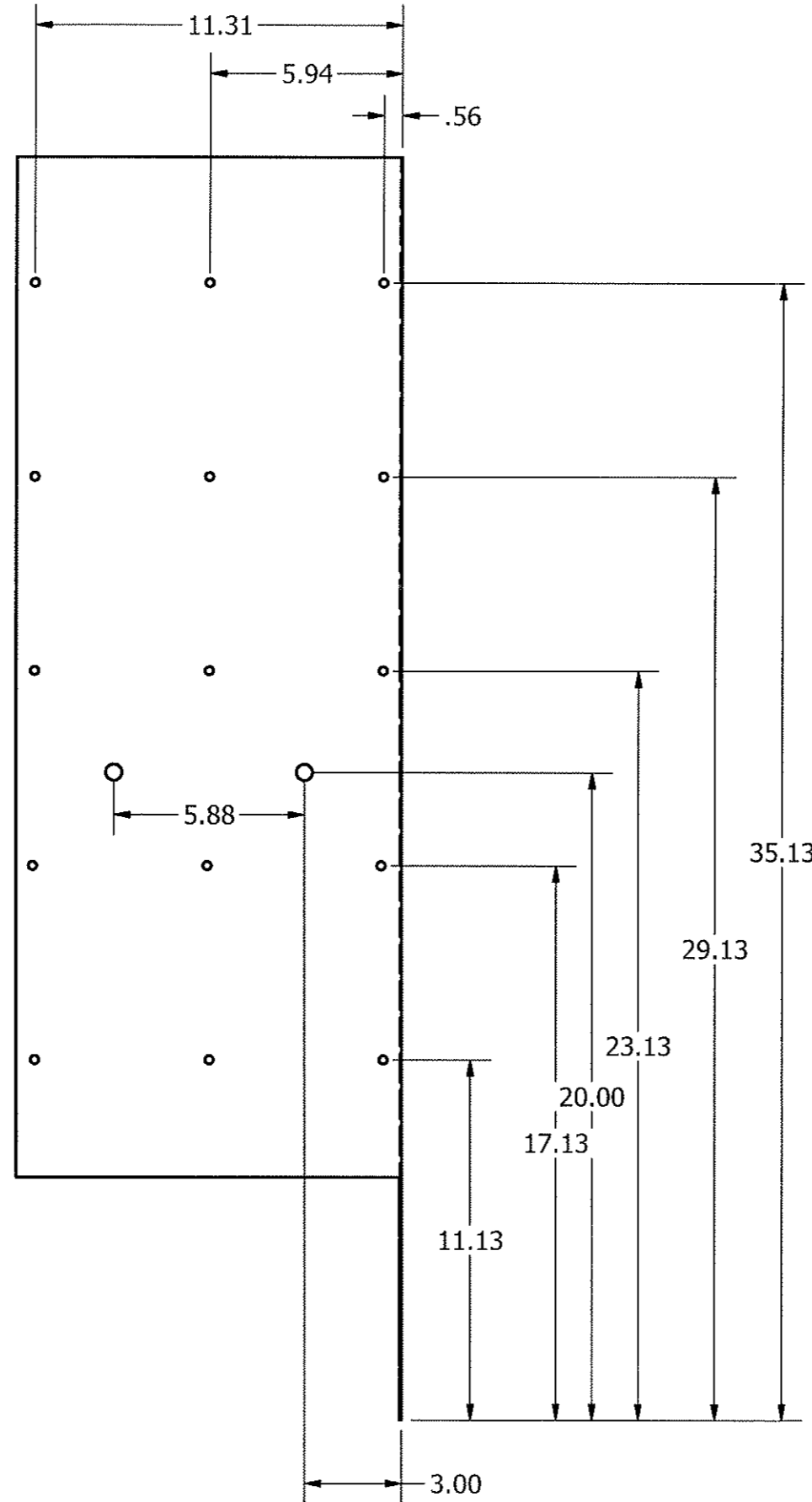
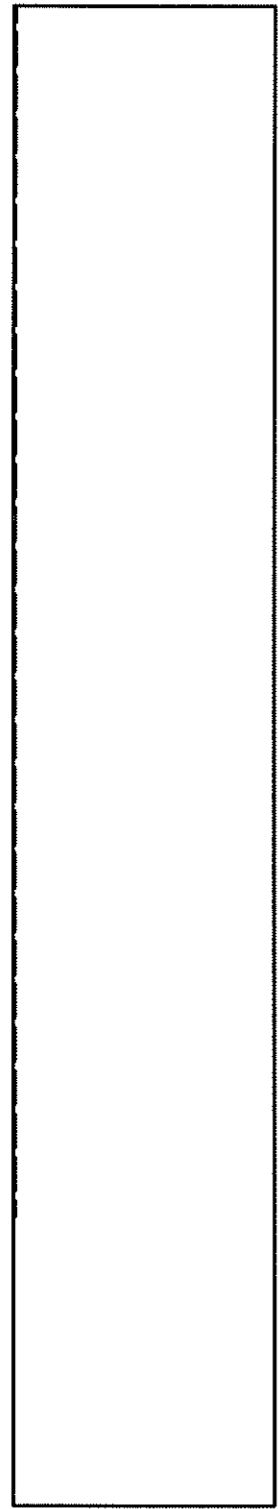
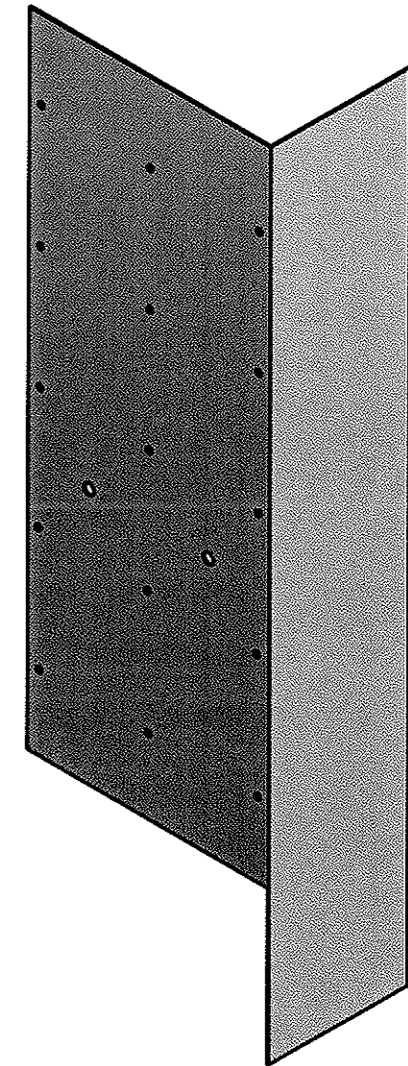

DRAWN	4/26/2010	TSU Sr. Projects: Fibergrate Clip Drilling Machine		
D.S. Frank		TITLE		
CHECKED		QA		
QA		MFG		
MFG		APPROVED		
APPROVED		SIZE	DWG NO	REV
		B	Vertical Magazine	
		SCALE	SHEET 5 OF 9	

B

B

A

A

A

A

4

3

2

1

NOTE: MATERIAL IS 1/4" STEEL PLATE

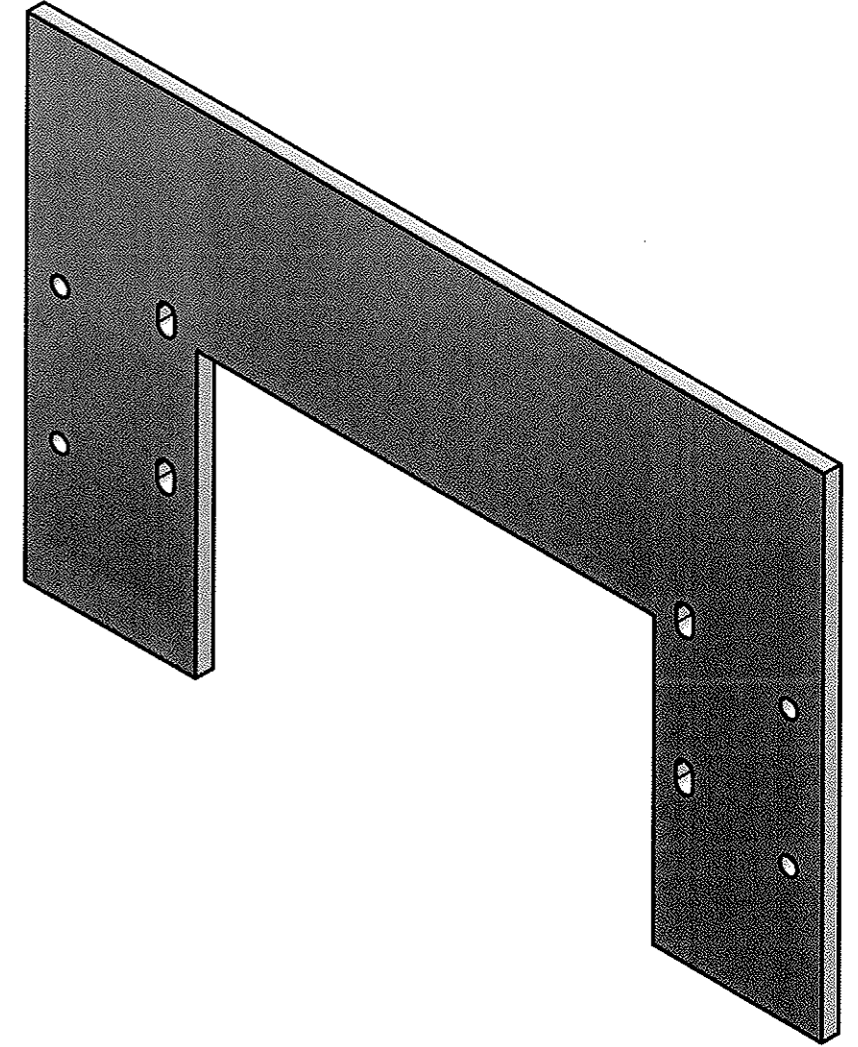
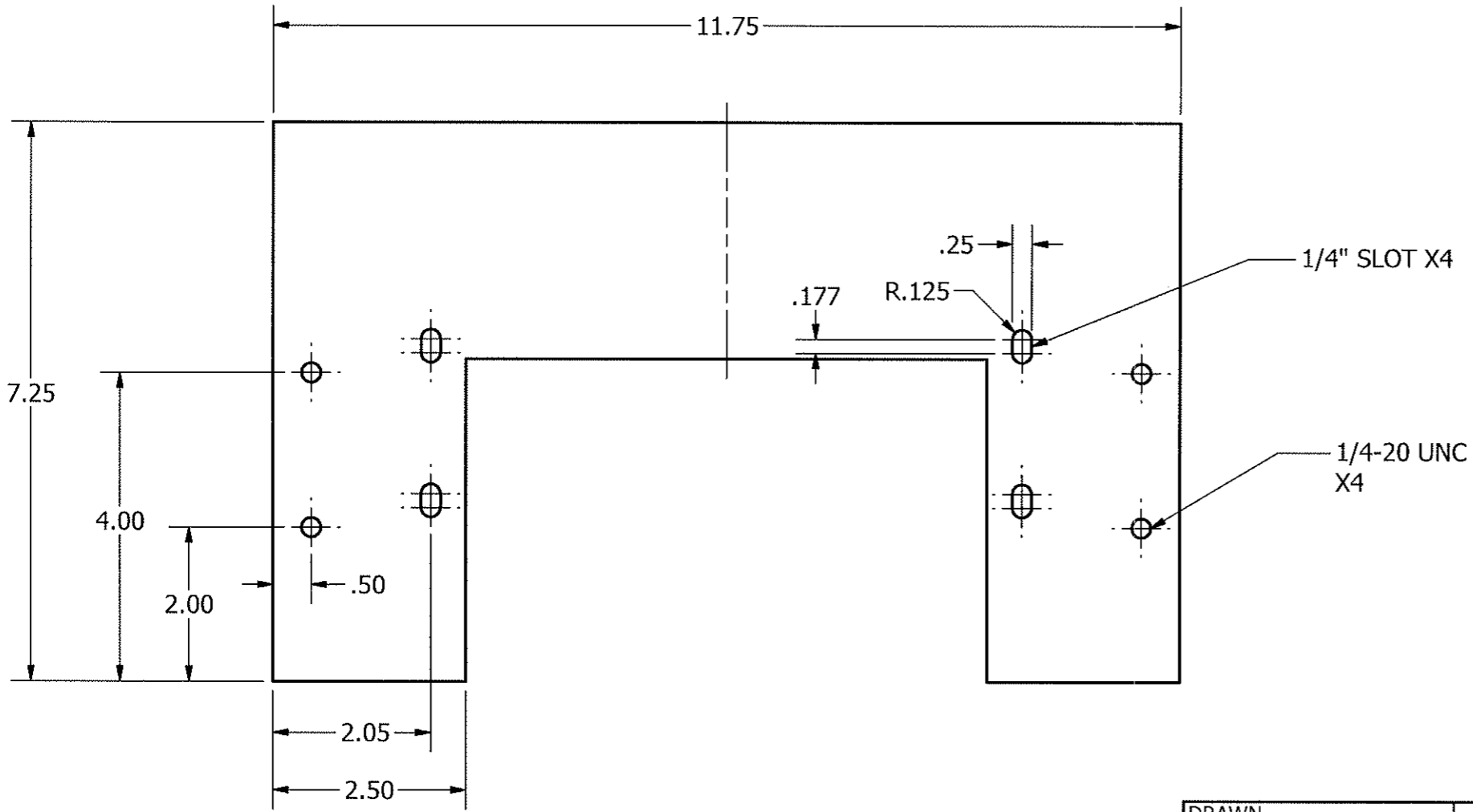

DRAWN		TSU Sr. Projects: Fibergrate Clip Drilling Machine		
D.S. Frank	4/26/2010	TITLE		
CHECKED		SIZE		
QA		DWG NO		
MFG		Vertical Magazine		
APPROVED		REV		
		SCALE	SHEET 6 OF 9	

NOTE: MATERIAL IS 1/4" STEEL PLATE

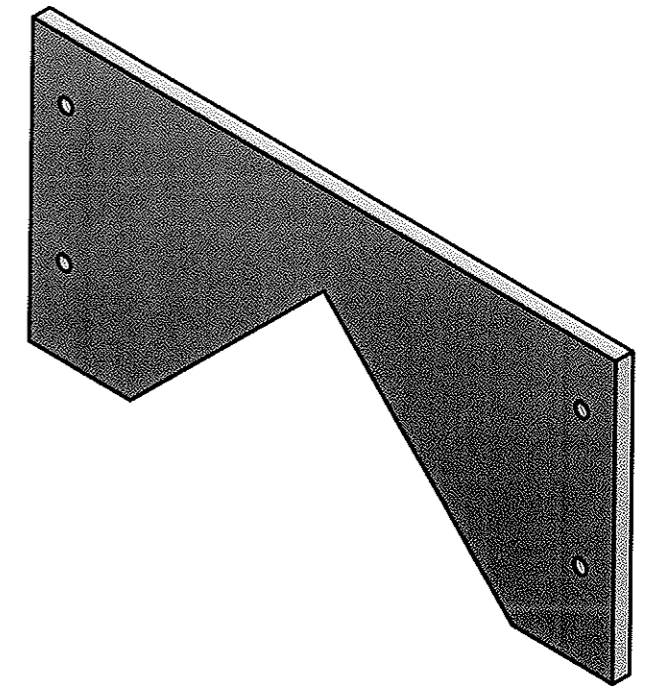
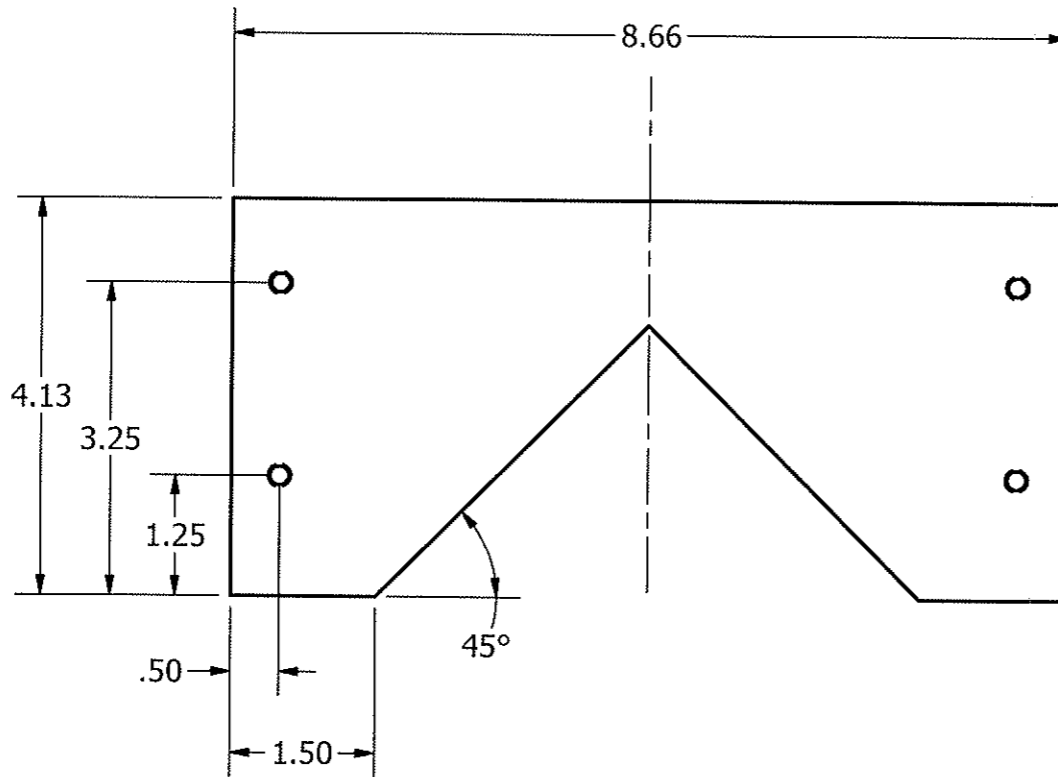

DRAWN D.S. Frank	4/26/2010	TSU Sr. Projects: Fibergrate Clip Drilling Machine		
CHECKED		TITLE		
QA				
MFG				
APPROVED				
		SIZE B	DWG NO	REV
			Vertical Magazine	
		SCALE	SHEET 7 OF 9	

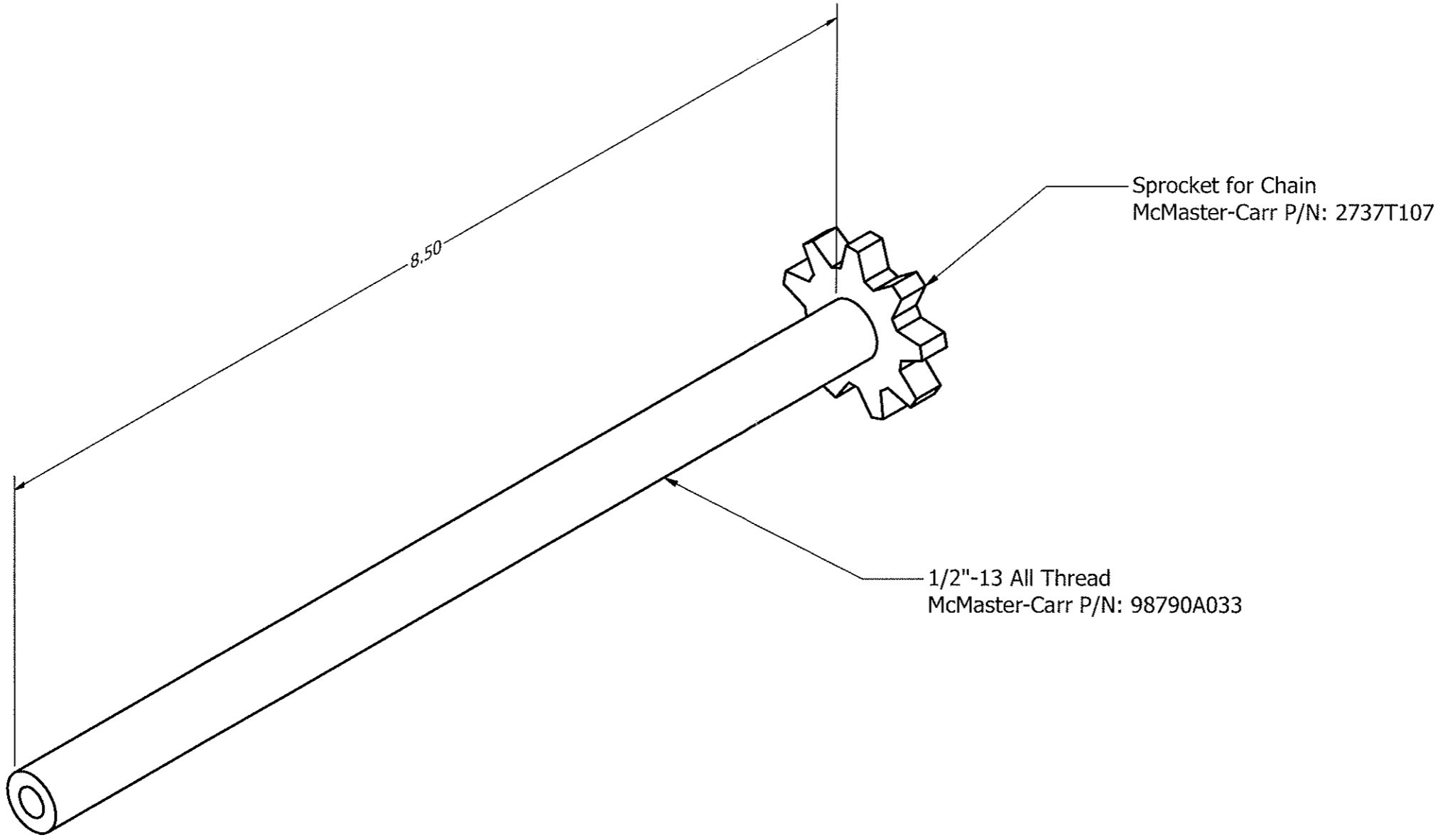

DRAWN		TSU Sr. Projects: Fibergrate Clip Drilling Machine		
D.S. Frank	4/26/2010	TITLE		
CHECKED				
QA				
MFG				
APPROVED		SIZE	DWG NO	REV
		B	Vertical Magazine	
		SCALE	SHEET 8 OF 9	

4

3

2

1

NOTE: MATERIAL IS 1/16" SHEET METAL

SUPPORT PLATE IS 1/4" STEEL PLATE

1/2"-13 UNC Tap THRU

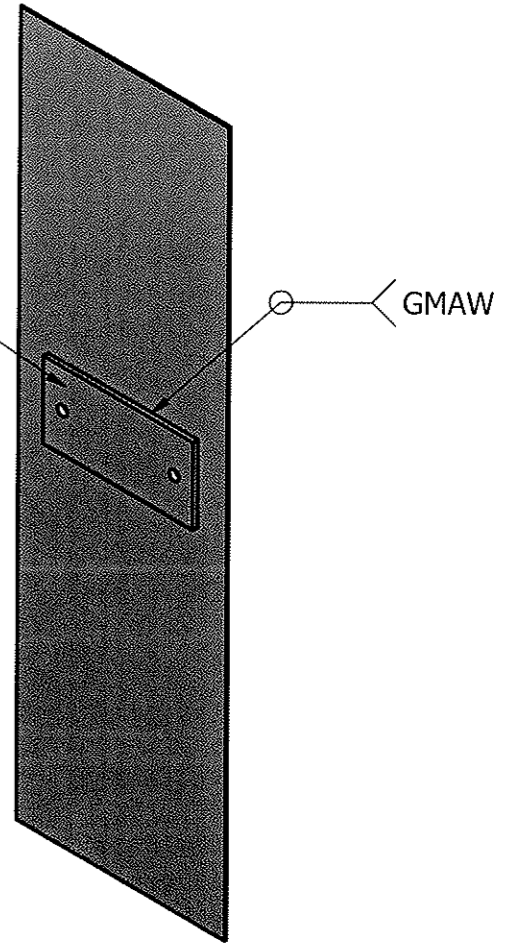
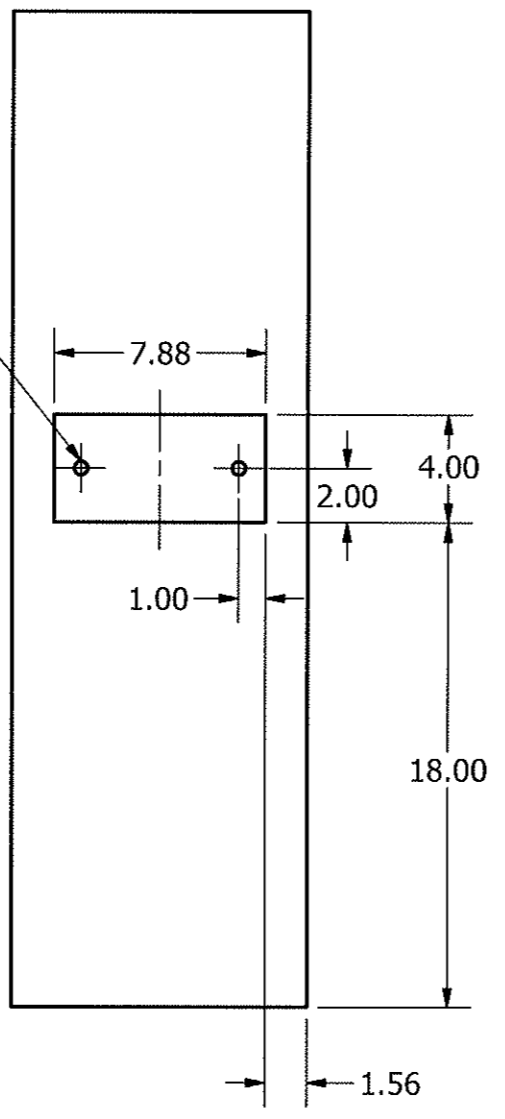

DRAWN	4/26/2010	TSU Sr. Projects: Fibergrate Clip Drilling Machine		
D.S. Frank		TITLE		
CHECKED				
QA				
MFG				
APPROVED		SIZE	DWG NO	REV
		B	Vertical Magazine	
		SCALE	SHEET 9 OF 9	

NOTE: QTY = 2

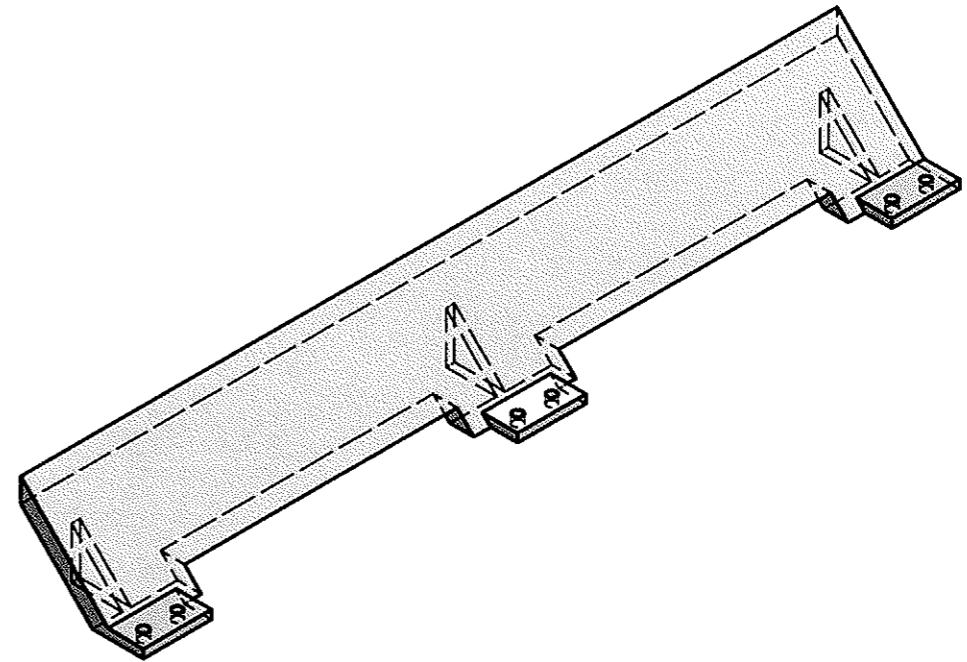
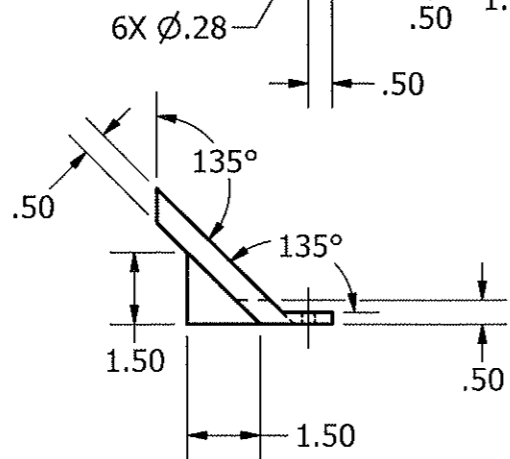
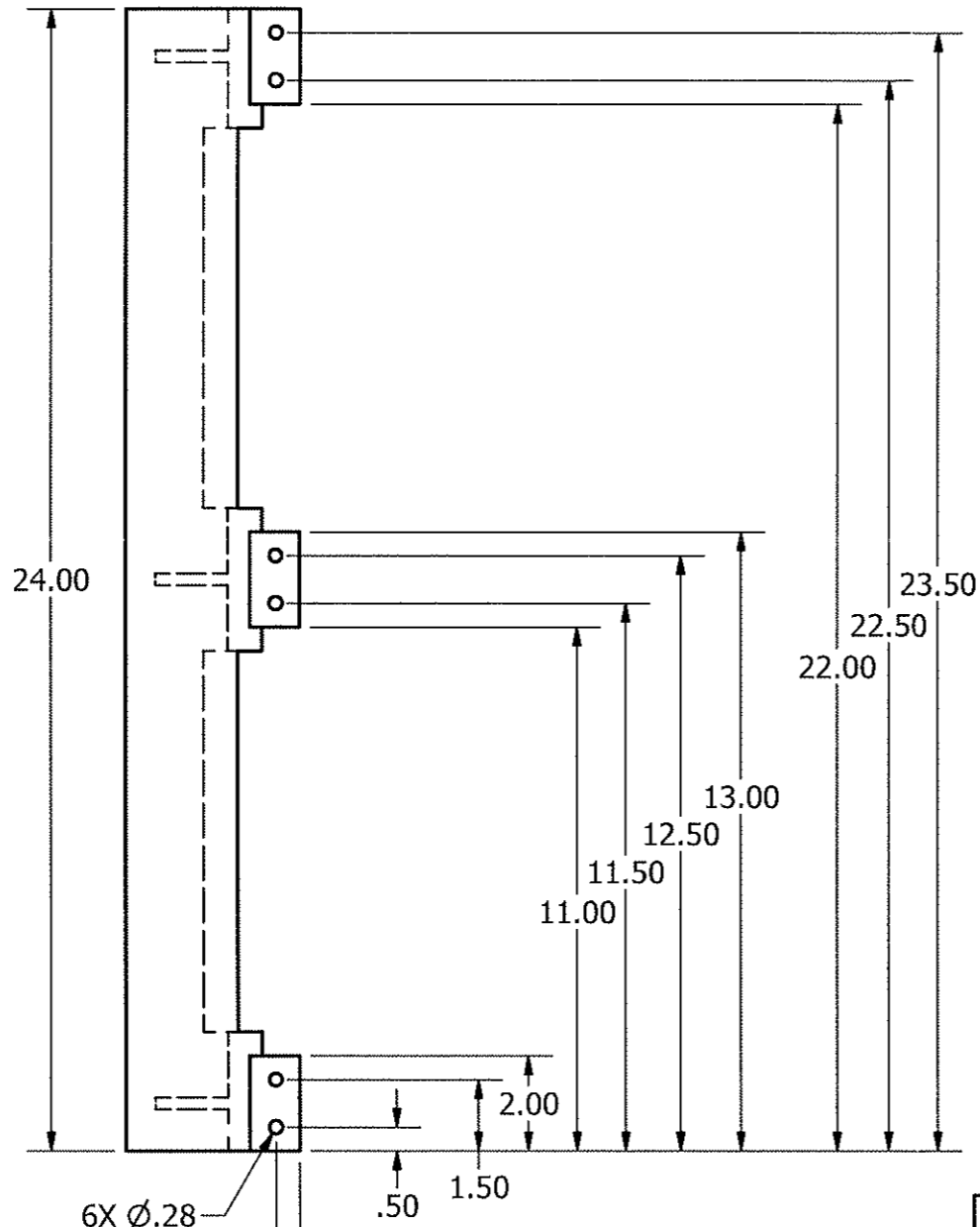
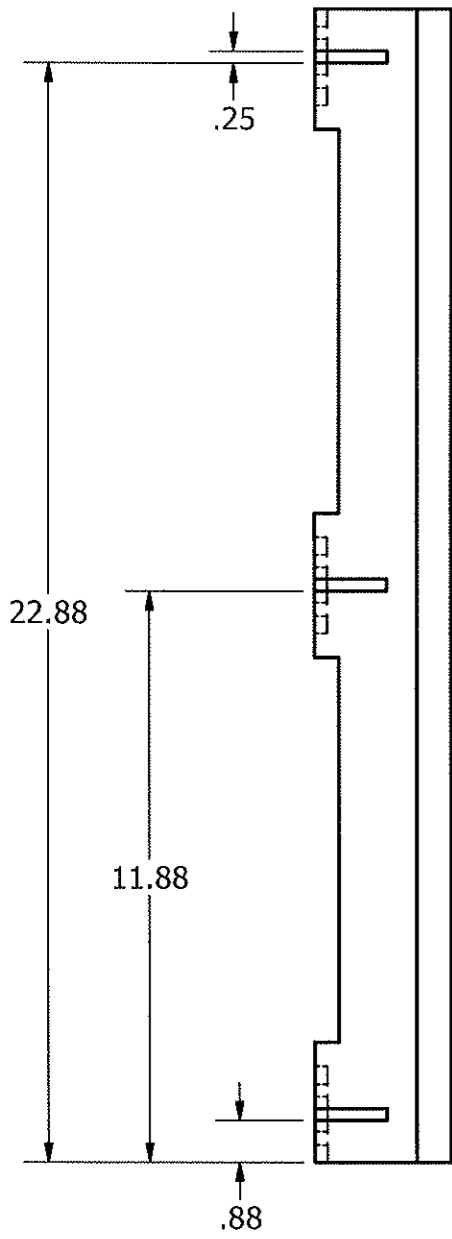

DRAWN D.S. FRANK	4/29/2010	TSU Sr. Projects: Fibergrate Clip Drilling Machine		
CHECKED		TITLE		
QA		Clip Rail		
MFG				
APPROVED				
		SIZE B	DWG NO Clip Rail	REV
		SCALE	SHEET 1 OF 1	

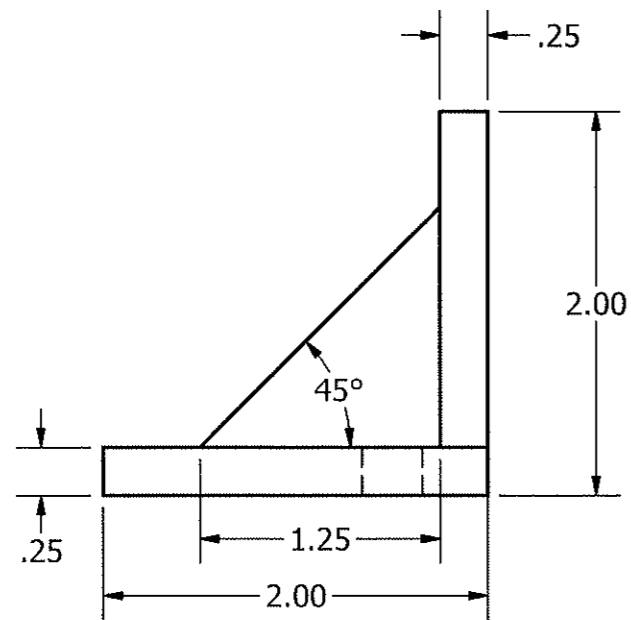
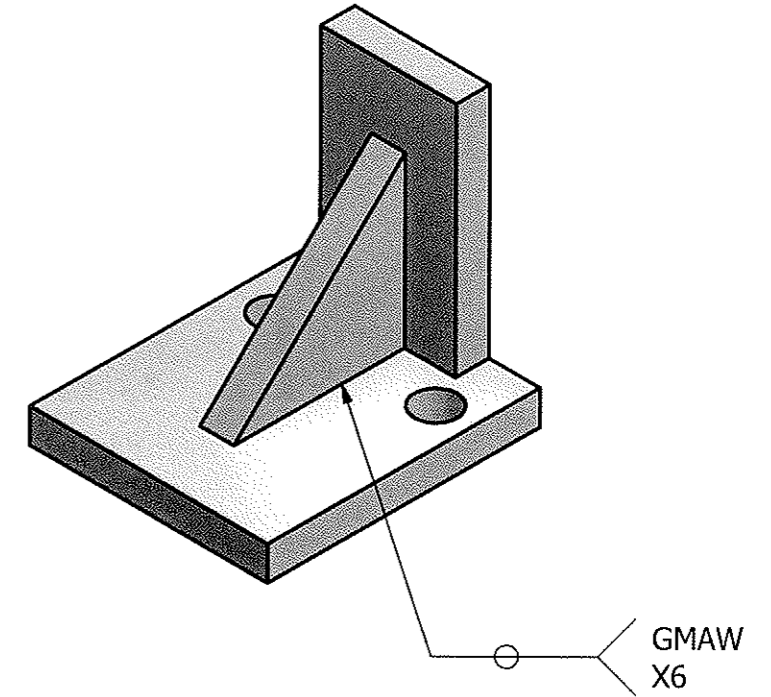
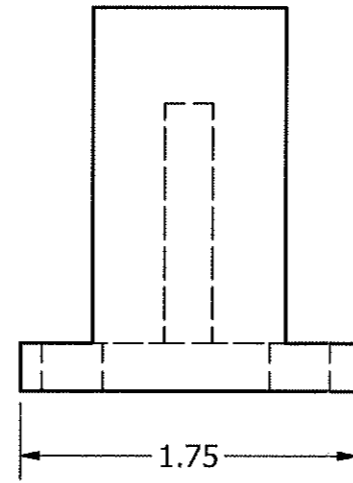
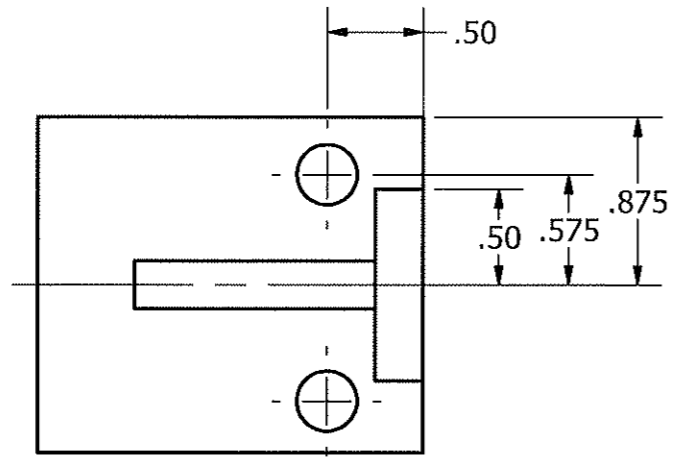

DRAWN	4/29/2010	TSU Sr. Projects: Fibergrate Clip Drilling Machine		
D.S. Frank		TITLE		
CHECKED		Dead Stop Flange		
QA		SIZE	DWG NO	REV
MFG		B	Dead Stop Flange	
APPROVED		SCALE	SHEET 1 OF 1	